

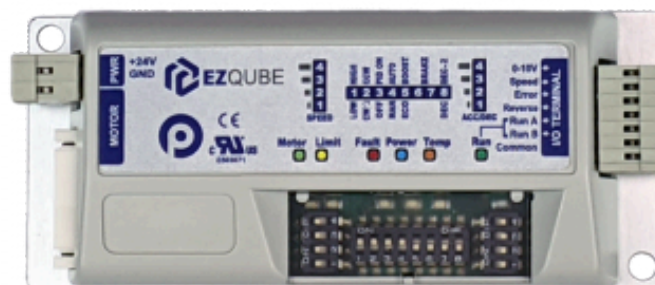

# EZ-QUBE Reference Manual

Version 3.0 — 26 August 2022



# Table of Contents

- 1. About This Manual ..... 2
- 2. Glossary of Terms ..... 5
- 3. Module Hardware..... 6
  - 3.1. Identifying Module Components ..... 7
    - 3.1.1. EZ-QUBE-N, -P, -P-MR, -P-J..... 7
    - 3.1.2. EZ-QUBE-HTBF-P, -N ..... 8
  - 3.2. Mounting Dimensions ..... 9
  - 3.3. Mounting Considerations .....10
  - 3.4. Power Connector .....12
  - 3.5. Motor Connector .....13
  - 3.6. I/O Connector .....14
  - 3.7. Inspection and Cleaning .....15
  - 3.8. Technical Specifications..... 16
- 4. Module Wiring.....18
  - 4.1. Power Supply ..... 18
  - 4.2. Proper Motor Grounding Practice .....20
  - 4.3. Run/Reverse Inputs .....20
    - 4.3.1. Single Module .....21
    - 4.3.2. Multiple Modules from Single Signal .....22
    - 4.3.3. Multiple Modules from Individual Signals .....25
  - 4.4. 0-10V Analog Input .....28
  - 4.5. Error Output.....30
    - 4.5.1. PNP Versions .....31
    - 4.5.2. NPN Versions .....34
  - 4.6. Speed Output.....36
    - 4.6.1. PNP Versions .....36
    - 4.6.2. NPN Versions .....38
- 5. DIP Switch Settings.....40
  - 5.1. CONFIG DIP Switch .....41
    - 5.1.1. Electronic Holding Brake Settings .....43
    - 5.1.2. Motor Performance Settings.....44
  - 5.2. SPEED DIP Switch .....45
    - 5.2.1. 0-10V Analog Speed .....46
    - 5.2.2. Speed Calculation.....48
  - 5.3. ACC/DEC DIP Switch .....49
    - 5.3.1. Accel/Decel Equal .....50
    - 5.3.2. Decel Equal 2 x Accel .....51
    - 5.3.3. Accel/Decel Time Formula.....53

- 6. Operation ..... 55
- 7. Output Signals & LED Indicators ..... 56
  - 7.1. Pulse Speed Output..... 56
  - 7.2. Error Output and LED Status ..... 58
    - 7.2.1. Power Supply ON with Motor Connected ..... 60
    - 7.2.2. Motor Not Connected..... 61
    - 7.2.3. Power Supply Voltage > 32V..... 62
    - 7.2.4. Voltage Drop Below 18V and Voltage Drop Below 13V..... 63
    - 7.2.5. Voltage Over 32V Due to Motor Overspeed ..... 64
    - 7.2.6. Normal Operation with Motor Running then Reverse Signal..... 65
    - 7.2.7. Motor Current Exceeding Peak Limit ..... 66
    - 7.2.8. Over Current with PWM Limiting ..... 67
    - 7.2.9. Motor Stalled with Self Stop..... 68
    - 7.2.10. Motor Overload with Self Stop ..... 69
    - 7.2.11. Module Over Heat with Self Stop ..... 70
    - 7.2.12. Motor Not Running when RUN is ON ..... 71
    - 7.2.13. Motor Phases Error Detected ..... 72
- 8. Internal Jumper Settings ..... 73

# 1. About This Manual

## Products Covered in this Manual

- EZ-QUBE-N - Article Number 1510-5000
- EZ-QUBE-P - Article Number 1510-6000
- EZ-QUBE-P-MR - Article Number 1510-6020
- EZ-QUBE-P-J - Article Number 1510-6040

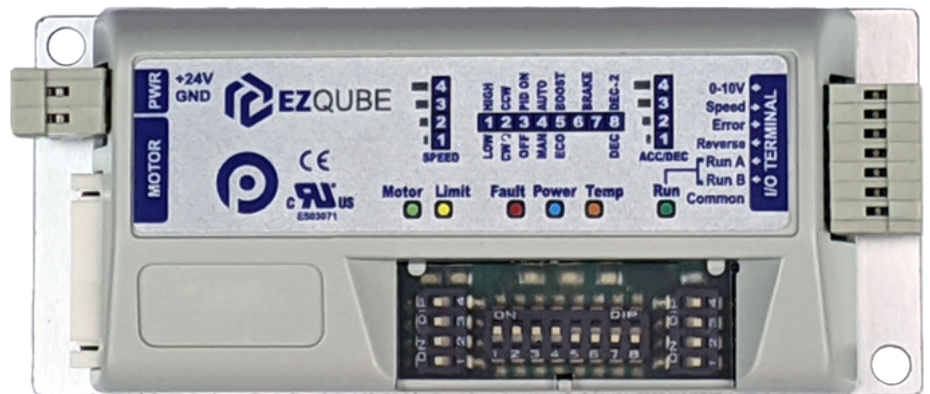

- EZ-QUBE-HTBF-P - Article Number 1510-4110
- EZ-QUBE-HTBF-N - Article Number 1510-4120

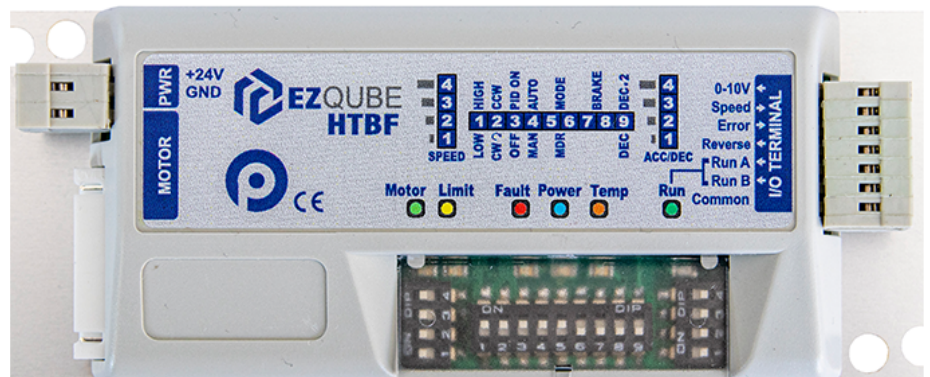

## Symbol Conventions

! This symbol indicates that special attention should be paid in order to ensure correct use as well as to avoid danger, incorrect application of product, or potential for unexpected results

\* This symbol indicates important directions, notes, or other useful information for the proper use of the products and software described herein

## Important User Information

! Modules contain ESD (Electrostatic Discharge) sensitive parts and components. Static control precautions are required when installing, testing, servicing or replacing these modules. Component damage may result if ESD control procedures are not followed. If you are not familiar with static control procedures, reference any applicable ESD protection handbook. Basic guidelines are:

- Touch a grounded object to discharge potential static
- Wear an approved grounding wrist strap
- Do not touch connectors or pins on component boards
- Do not touch circuit components inside the equipment
- Use a static-safe workstation, if available
- Store the equipment in appropriate static-safe packaging when not in use

! Because of the variety of uses for the products described in this publication, those responsible for the application and use of this control equipment must satisfy themselves that all necessary steps have been taken to assure that each application and use meets all performance and safety requirements, including any applicable laws, regulations, codes, and standards

! The illustrations, charts, sample programs and layout examples shown in this guide are intended solely for purposes of example. Since there are many variables and requirements associated with any particular installation, Pulseroller does not assume responsibility or liability (to include intellectual property liability) for actual use based on the examples shown in this publication

! Reproduction of the contents of this manual, in whole or in part, without written permission of Pulseroller is prohibited

## Not Included in this Manual

! Because system applications vary; this manual assumes users and application engineers have properly sized their power distribution capacity per expected motor loading and expected operational duty cycle. Please refer to conveyor equipment and/or motor roller manufacturer's documentation for power supply sizing recommendations

## How to Contact Us

Technical Support North & South America: [support@pulseroller.com](mailto:support@pulseroller.com)

Sales Support North & South America: [sales@pulseroller.com](mailto:sales@pulseroller.com)

Technical Support Global: [global\\_support@pulseroller.com](mailto:global_support@pulseroller.com)

Sales Support Global: [global\\_sales@pulseroller.com](mailto:global_sales@pulseroller.com)

Web Site: [www.pulseroller.com](http://www.pulseroller.com)

## 2. Glossary of Terms

Term	Definition
Brushless DC Motor	A D.C. motor with a permanent magnet rotor and coils in the stator. The stator coil currents are sequenced by an external brushless D.C. motor controller. In such motors, current and torque, voltage and rpm are linearly related. The main advantage to this type of motor is the elimination of EMI caused by the arcing brushes and improved motor life
Hall Effect Sensor	Special sensor embedded within the brushless DC motor of an MDR used to provide motor rotor position feedback to the motor controller
JST	This is the name of a particular connector manufacturer that produces a specific plug/socket arrangement for MDR connection to control cards. This name is accepted within the conveyor and MDR industry as a simple description of the particular socket style used on EZ-QUBE hardware.
LED	Light Emitting Diode – In the context of this document, LED's are used on the EZ-QUBE to provide visual indication of module status
MDR	Motorized Drive Roller or Motor Driven Roller – Brushless DC motor and gearbox assembly integrated into a single conveyor roller
NPN / PNP	Electronics term that indicates the type of transistor circuit used for a logical input or output for controllers. NPN devices will provide a common or ground connection when activated and a PNP device will provide a logic voltage connection when activated
PLC	Programmable Logic Controller – A wide variety of industrial computing devices that control automatic equipment
PWM	Pulse Width Modulation – a control scheme that utilizes high speed switching transistors to efficiently deliver power in a controlled fashion from the EZ-QUBE controller to MDR
Senergy ECO	Mode of performance that provides the highest speed for the selected gear reduction option of the PulseRoller Senergy brand motor roller and gear drive units
Senergy BOOST	Mode of performance that provides the highest torque for the selected gear reduction option of the Pulseroller Senergy brand motor roller and gear drive units

## 3. Module Hardware

---

EZ-QUBEs are designed to be installed and integrated into the conveyor's mechanical side frame assembly. The EZ-QUBE is a controller for a single Senergy brand Motorized Drive Roller (MDR) or Senergy brand Pulse Gear Drive (PGD) unit.

### Module Features

- Over-voltage protection with transient voltage suppressor
- Internal SMD fast 8 Amp fuse
- Protection from over-voltage produced by over-speeding of MDR
- Thermal and Over-Current Protection for module and MDR
- Reverse polarity protection against incorrect wiring of the power terminals
- Sensing and indication of over voltage from power supply and/or MDR (32 Volts)
- Sensing and indication of under voltage from power supply (18 Volts)
- PID speed regulation mode with 31 fixed speed settings
- Adjustable acceleration and deceleration with 16 fixed settings
- External 0-10V analogue voltage variable speed control
- Selectable Dynamic, Free Spin, and Servo brake control modes
- Automatic error recovery
- Six status LEDs
- Removable power and control signal terminal blocks
- Motor reversing capability while motor is running.
- Error Output signal and LED indication for module and MDR diagnosis
- Speed Output signal and LED indication for speed of MDR
- Over-Current Protection for Error and Speed Outputs
- Selectable default rotation direction
- Hinged clear protective cover for DIP Switch and LEDs
- Options for PNP or NPN control signal wiring accommodation
- Run signal inputs are galvanically isolated
- Selectable ECO and BOOST modes of operation

Learn more:

[Identifying EZ-QUBE Components](#)

[Mounting Dimensions](#)

[Motor Ports](#)

[LED Status Indicators](#)



# 3.1. Identifying Module Components

[EZ-QUBE-N, -P, -P-MR, -P-J](#)

[EZ-QUBE-HTBF-P, -N](#)

## 3.1.1. EZ-QUBE-N, -P, -P-MR, -P-J

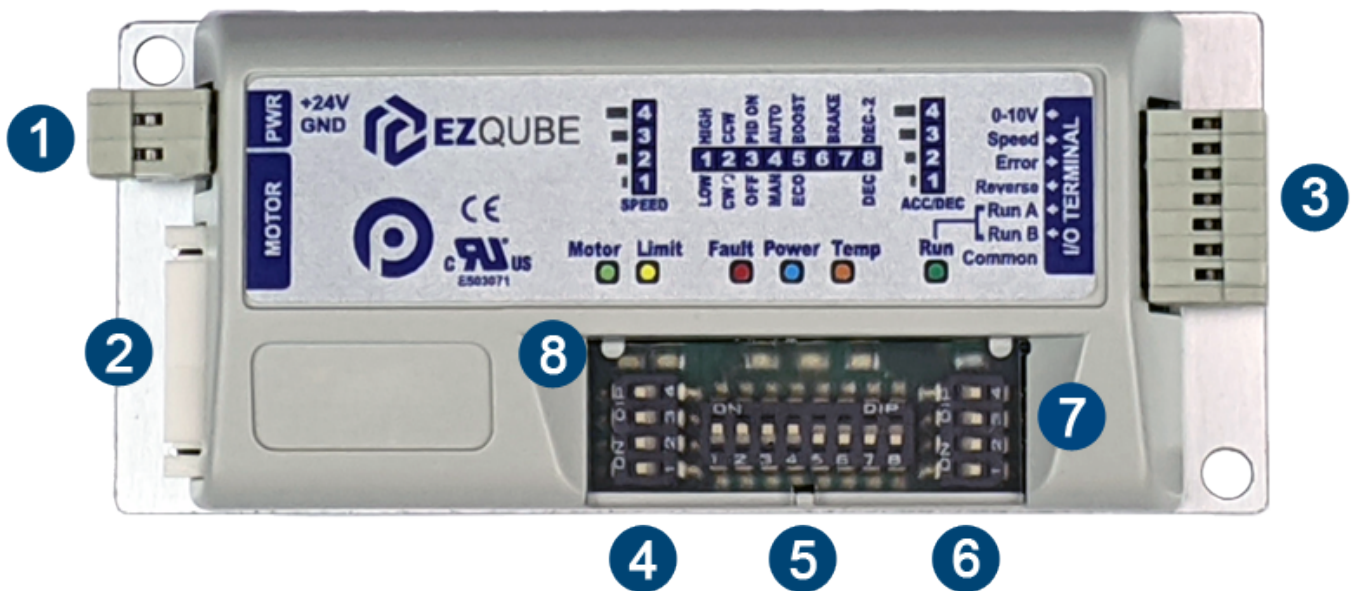

Item	Description
1	Removable 24VDC Power Connector Terminal Block
2	Senergy Motor Port - 9-pin JST style header for MDR/PGD connection
3	Removable I/O Terminal Block
4	Motor Speed Selection 4 Position DIP Switch
5	Configuration 8 Position DIP Switch

<b>6</b>	Motor Accel/Decel 4 Position DIP Switch
<b>7</b>	DIP Switch and LED Hinged Clear Protective Cover
<b>8</b>	Module Status LEDs

### 3.1.2. EZ-QUBE-HTBF-P, -N

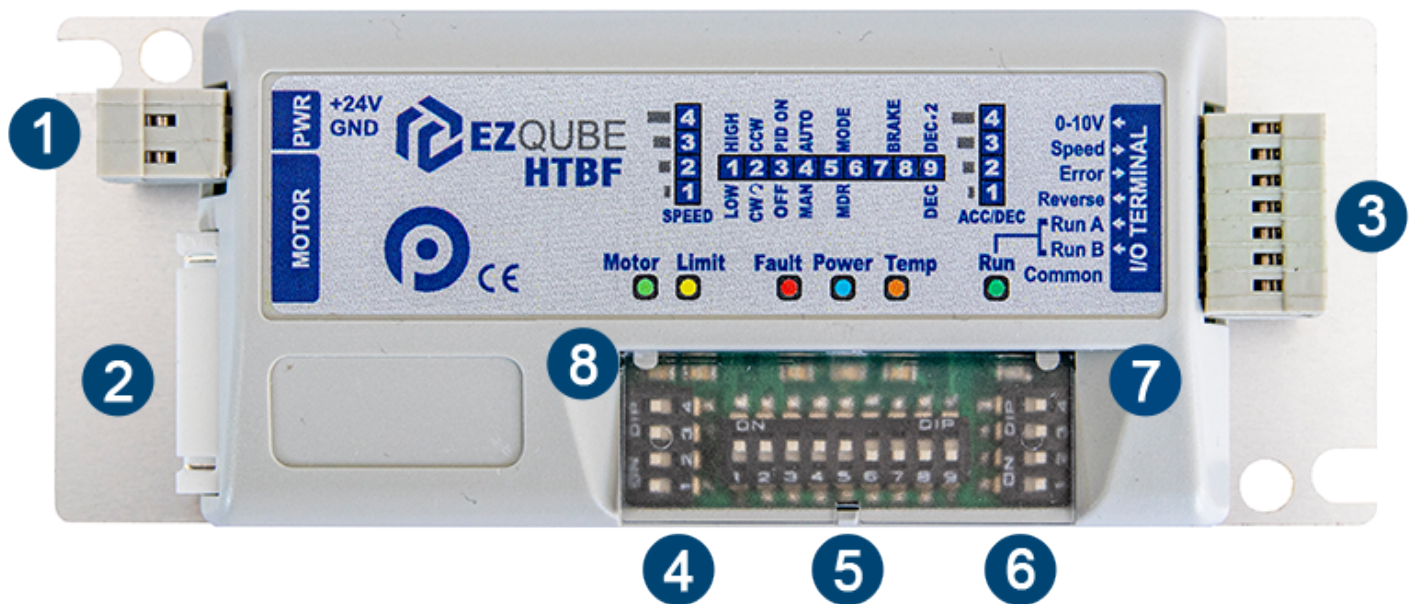

Item	Description
<b>1</b>	Removable 24VDC Power Connector Terminal Block
<b>2</b>	Senergy Motor Port - 9-pin JST style header for MDR/PGD connection
<b>3</b>	Removable I/O Terminal Block
<b>4</b>	Motor Speed Selection 4 Position DIP Switch

<b>5</b>	Configuration 9 Position DIP Switch
<b>6</b>	Motor Accel/Decel 4 Position DIP Switch
<b>7</b>	DIP Switch and LED Hinged Clear Protective Cover
<b>8</b>	Module Status LEDs

## 3.2. Mounting Dimensions

### EZ-QUBE-N / EZ-QUBE-P / EZ-QUBE-P-MR / EZ-QUBE-P-J

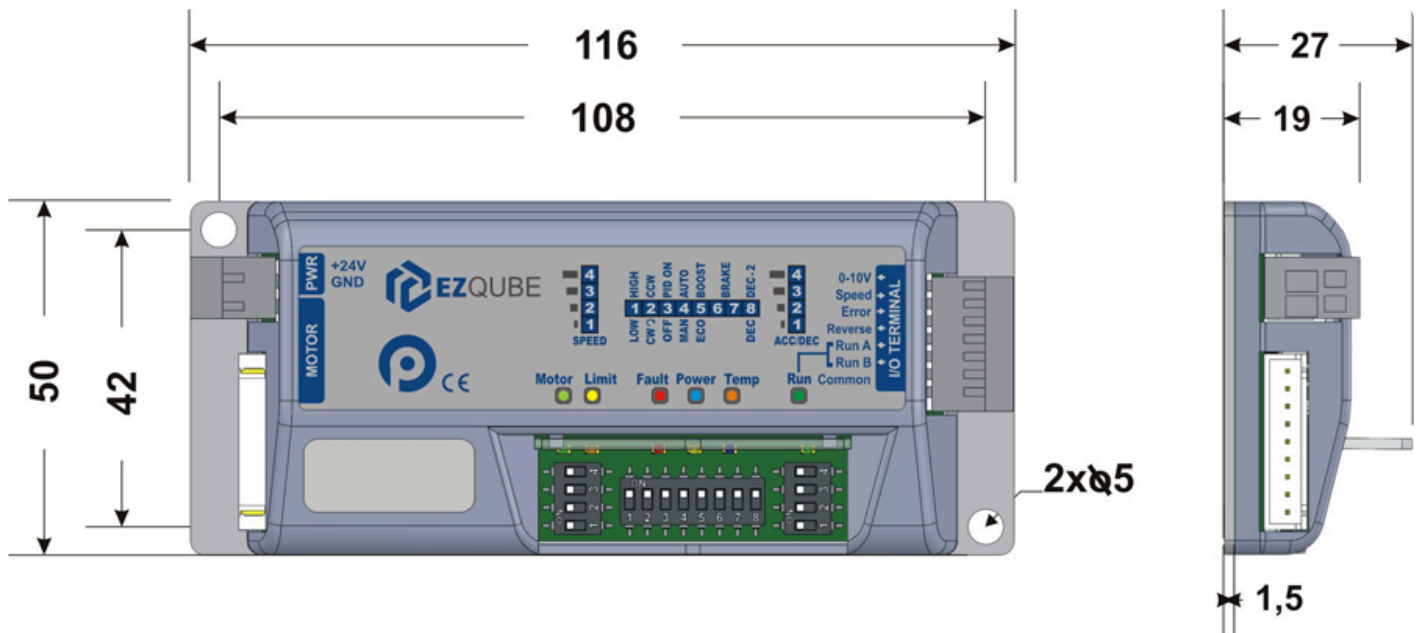

## EZ-QUBE-HTBF-P / EZ-QUBE-HTBF-N

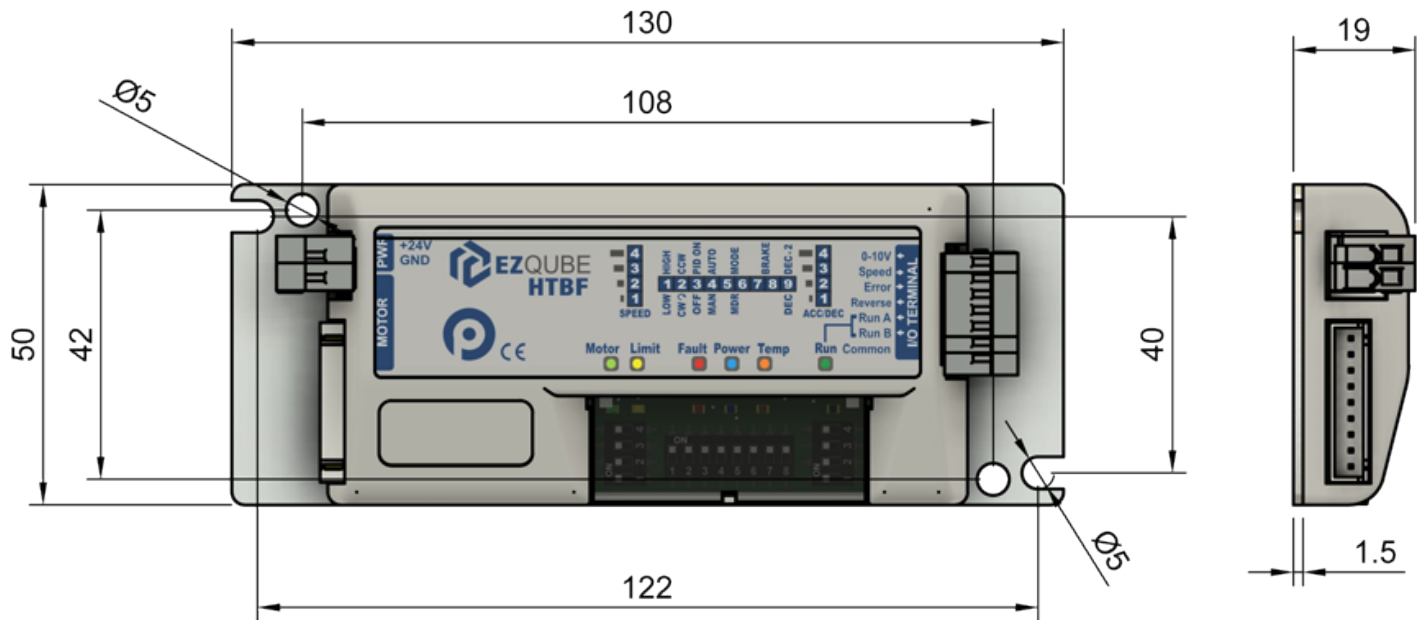

### 3.3. Mounting Considerations

EZ-QUBE module must be mounted with its long side parallel to the conveyor frame and with its heat sink plate in contact with the conveyor frame. Attach module to frame using fasteners through the 2 mounting holes on the module through matching holes drilled into conveyor frame.

Other mounting and installation requirements:

- Metal Heat Sink surface must face the conveyor frame and Heat Sink must not be accessible by any personnel without removing the module from the frame
- Module must be mounted on electrically grounded metal surface or provided with a conductor wire connecting the module's metal heat sink plate to electrical ground.
- Module must be mounted in such a way such that there are no interferences with an operator's ability to remove or unplug the power, motor, and control signal connectors.
- Module should be mounted in such a way and location such that any personnel can easily retreat away from the module in the event of a device failure
- Module must be mounted such that it can be accessed by personnel of any height

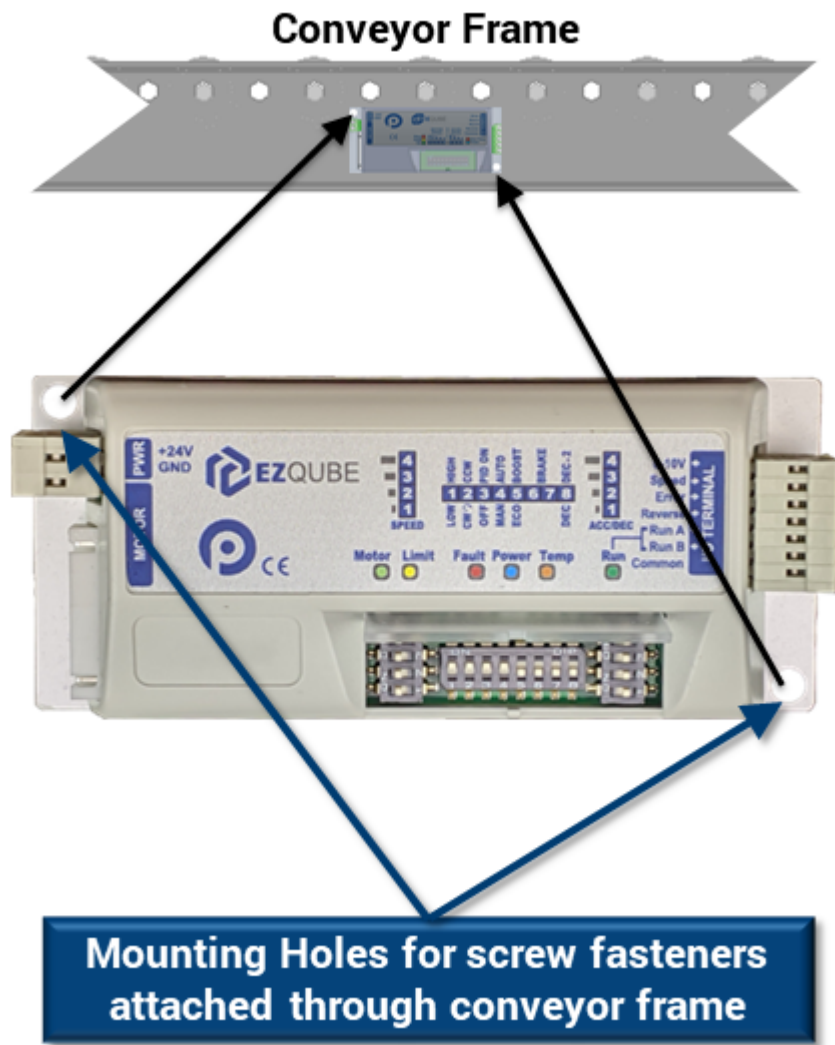

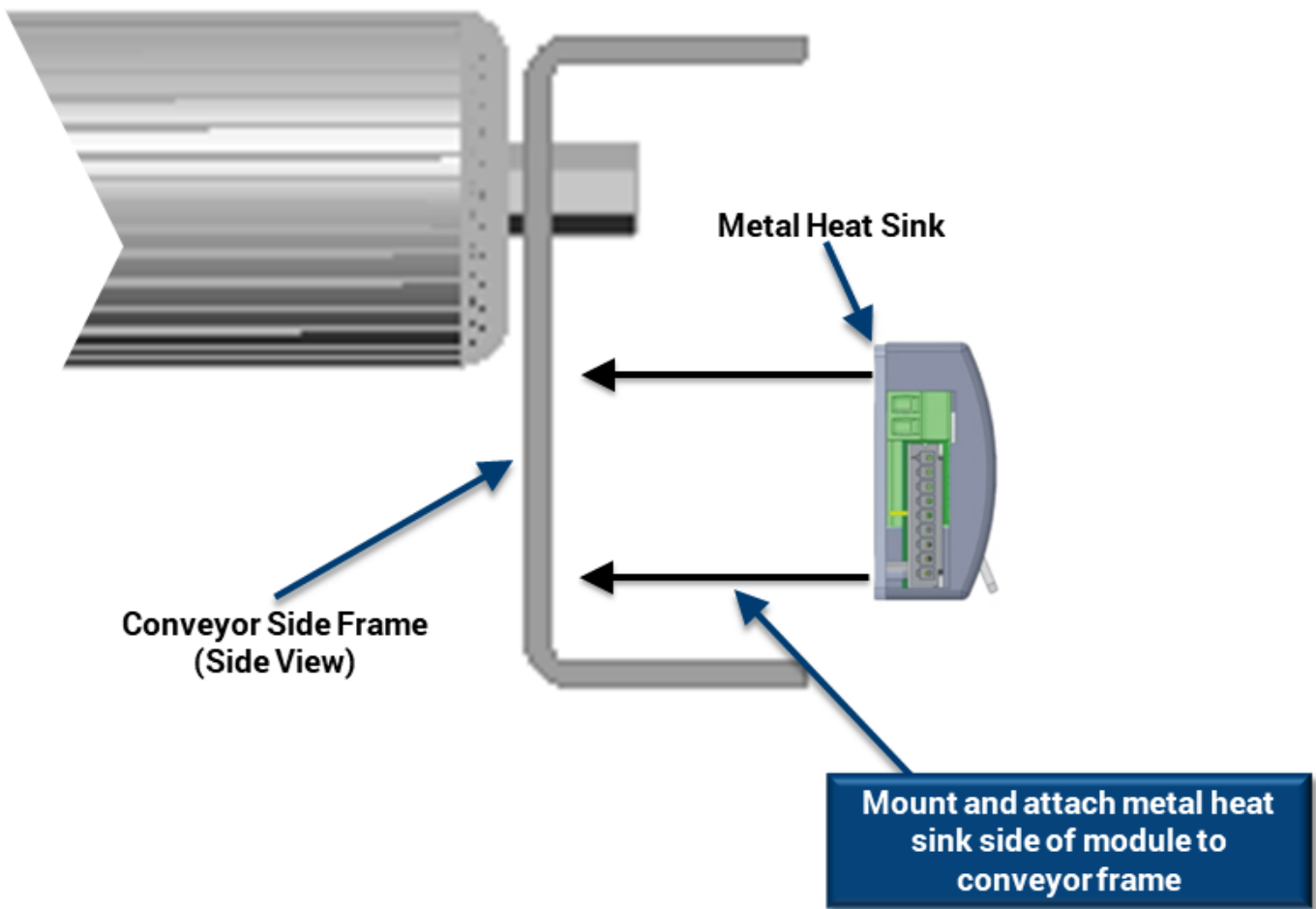

### 3.4. Power Connector

---



Power Connector Plug	
Part Number	Degson 8EDGK-3.5-02P-11

Wire Size	28 - 14 AWG (0.2 - 1.5 mm <sup>2</sup> )
Strip Length	5 - 6 mm

Pin	Signal	Description
1	+24VDC	Module 24VDC Supply
2	GND	0V DC Common

Wire terminals on all removable connectors are “cage-clamp” style requiring a small blade screwdriver to open the clamp to insert the wire

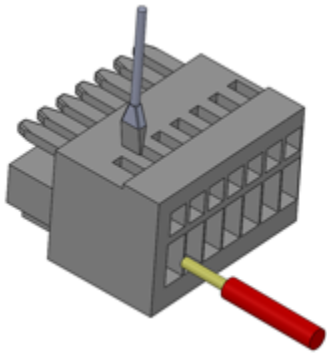

## 3.5. Motor Connector

The EZ-QUBE motor port is a 9 pin JST Style connector that accommodates Pulseroller Senergy motor rollers and PGD units.



Pin	Description
1	GND
2	Vcc - Hall Effect Sensor Power
3	Motor Winding U
4	Motor Winding V
5	Motor Winding W
6	Hall Effect Sensor U
7	Hall Effect Sensor V
8	Hall Effect Sensor W
9	Not Used for EZ-QUBE-N, -P, P-MR, -P-J Mechanical Brake control for EZ-QUBE-HTBF-N, -P

\* Please note the JST connector is keyed so you cannot plug it in upside down

## 3.6. I/O Connector



Wire terminals on all removable connectors are “cage-clamp” style requiring a small blade screwdriver to open the clamp to insert the wire

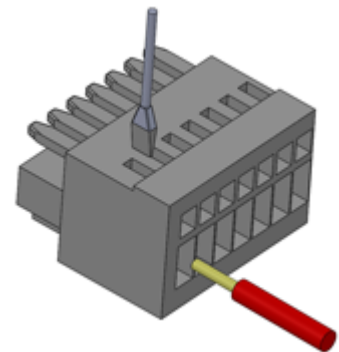

I/O Connector Plug	
Part Number	Degson 8EDGK-2.5-07P-11



Wire Size	28 - 20 AWG (0.2 - 0.5 mm <sup>2</sup> )
Strip Length	5 - 6 mm

Pin	Signal	Direction	Description
1	0-10V	Input	0-10 Volt analog input for speed control
2	Speed	Output	Outputs frequency proportional to the speed of the MDR
3	Error	Output	Provides +24V or 0V output when Error condition is active
4	Reverse	Input	Accepts +24V or 0V input to run motor in opposite direction that is set on DIP Switch "CONFIG"-2
5	Run A	Input	Accepts +24V or 0V input for run at speed control (see section Run A and Run B Inputs)
6	Run B	Input	Accepts +24V or 0V input for run at speed control (see section Run A and Run B Inputs)
7	Common	PNP Versions	DC common for optocouplers of Inputs (Run A, Run B, Reverse)
		NPN Versions	+24V common for optocouplers of Inputs (Run A, Run B, Reverse)

**!** For EZ-QUBE-P-J (Article Number 1510-6040), the COMMON terminal is internally connected to the module's 0v DC Common.  
All other PNP versions require a 0V DC Common connection to COMMON terminal.  
All NPN versions require +24V connection to COMMON terminal.

## 3.7. Inspection and Cleaning

When inspecting the device, the operator or maintenance personnel should visually inspect all mechanical parts and connections. The inspection should be performed on a monthly basis unless the device is not functioning as expected.

**!** In case of damage or if specific maintenance is required, it should be handled only by the manufacturer or buy a technician authorized by the manufacturer to perform such maintenance

For cleaning, use dry or slightly damp piece of cloth to wipe off the exterior of the module. Do

not use solvents or abrasives.

**!** Do not allow any liquids to penetrate inside the module cover. Any liquids inside the cover may result in damage

## 3.8. Technical Specifications

Input Power Supply Requirements	24.0VDC +15% / - 25%	
Standby Current Consumption	< 30 mA without Motor	
Built-in Current Limits	Max. Peak Current	16 A
	Max. Starting Current ECO Mode	3A
	Max. Rated Current ECO Mode	2.5A
	Max. Starting Current BOOST Mode	5A for 1.5 seconds
	Max. Rated Current BOOST Mode	3.5A
	Max. Starting Current BOOST 8 Mode (EZ-QUBE-HTBF-P, -N Only)	8A for 1.5 seconds
	Max. Rated Current BOOST 8 Mode (EZ-QUBE-HTBF-P, -N Only)	3.5A
Motor PWM Frequency	33.3 kHz +/- 0.1%	
Digital Input Minimum ON Current	1.5 mA	
Digital Input Maximum OFF Current	0.4 mA	
Initialization Time	<= 20 msec from power on	
Motor Start	<= 5 msec	

Response	
Storage temperature	-40°C to 85°C ( -40°F to 185°F)
Ambient Operating temperature	-10°C to 40°C ( 15°F to 104°F) -25°C to 40°C (-13°F to 104°F) EZ-QUBE-HTBF-P, -N Only
Humidity	5% to 95% non-condensing
Enclosure IP Rating	IP20 - Indoor Use Only
Altitude	up to 2000m
Environmental Pollution	Class 2
Weight	Approximately 70g

## 4. Module Wiring

---

[Power Supply](#)

[Motor Grounding Practice](#)

[Run/Reverse Inputs](#)

[Analog Input](#)

[Error Output](#)

[Speed Output](#)

### 4.1. Power Supply

---

#### Power Supply Requirements

The power supply for any and all EZ-QUBE modules should meet the following requirements:

- Certified as a NEC Class II device
- Capable of detecting and properly handling short circuit and overload of its DC power output
- Capable of supplying 24VDC at a minimum of 5 A for 1.5 seconds (BOOST Mode starting current time)

# Power Supply Grounding

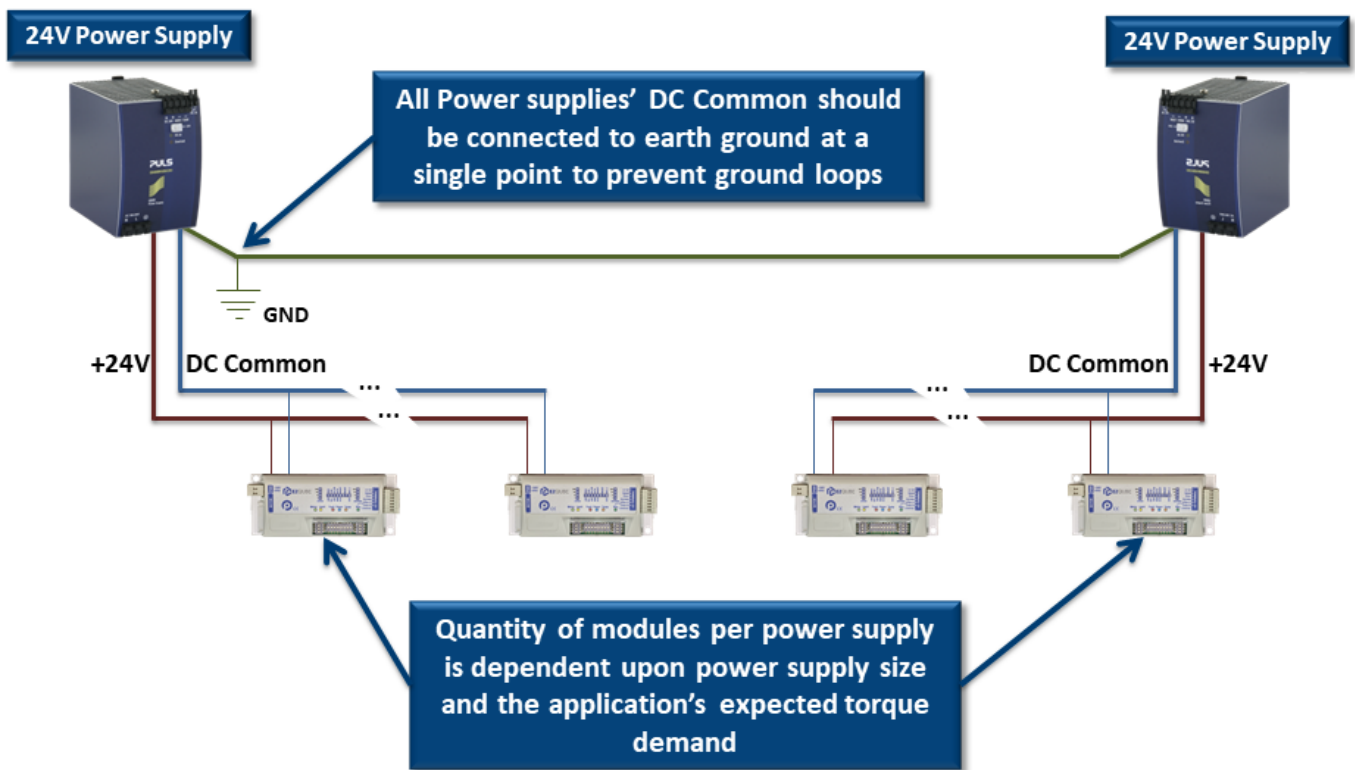

**!** Improper grounding of MDR and/or Power Supply Common may result in premature MDR and/or EZ-QUBE module failure. Proper grounding techniques MUST be observed for all applications

# Power Supply Sizing

The current loading on the power supply for a group of EZ-QUBEs depends upon the Motor Type selected. Each of the motor types available has an associated rated current that the motor will draw at rated torque and maximum speed. Each motor type also has an associated allowed current draw that is available for a period of time upon the initial starting of the motor. These current values and starting times are shown in the following chart:

	ECO	BOOST	BOOST 8
Power supply load at rated torque at maximum speed	2.5 A	3.5 A	3.5 A
Power supply load during motor starting period	3.0 A	5.0 A	8.0 A

Duration of motor starting period	1.5 sec	1.5 sec	1.5 sec
-----------------------------------	---------	---------	---------

\* The current values are at rated speed and at rated torque. The current will be less if rated torque is not required by the motor.

\* BOOST 8 only available on EZ-QUBE-HTBF-P, -N

## 4.2. Proper Motor Grounding Practice

Motor roller drive end shaft and/or fixing bracket must be electrically bonded to the conveyor frame and conveyor frame connected to electrical ground.



! Improper grounding of MDR and/or Power Supply Common may result in premature MDR and/or EZ-QUBE module failure. Proper grounding techniques MUST be observed for all applications

## 4.3. Run/Reverse Inputs

The *Run/Reverse* inputs on all EZ-QUBE modules (EXCEPT EZ-QUBE-P-J Article Number 1510-6040) can be wired to accept *either* PNP or NPN source signals.

\* The PNP and NPN versions of EZ-QUBE refer to how the ERROR and SPEED OUTPUTS are electrically configured at the factory. NPN or PNP EZ-QUBE part number designations do not apply to the signal source for the Run/Reverse inputs.

! To use the REVERSE input, either RUN A or RUN B must also be energized. Please note that you DO NOT have to de-energize both RUN A and RUN B signals in order to change MDR direction with the REVERSE input.

## Single Module Wiring

### Wiring Multiple Modules in Parallel with Single Output

### Wiring Multiple Modules in Parallel with Individual Outputs

## 4.3.1. Single Module

### Single Module Wiring (all models EXCEPT EZ-QUBE-P-J Article Number 1510-6040)





## Single Module Wiring for EZ-QUBE-P-J (Article Number 1510-6040)



## 4.3.2. Multiple Modules from Single Signal



# Wiring Multiple Modules with Single Signal (all models EXCEPT EZ-QUBE-P-J Article Number 1510-6040)

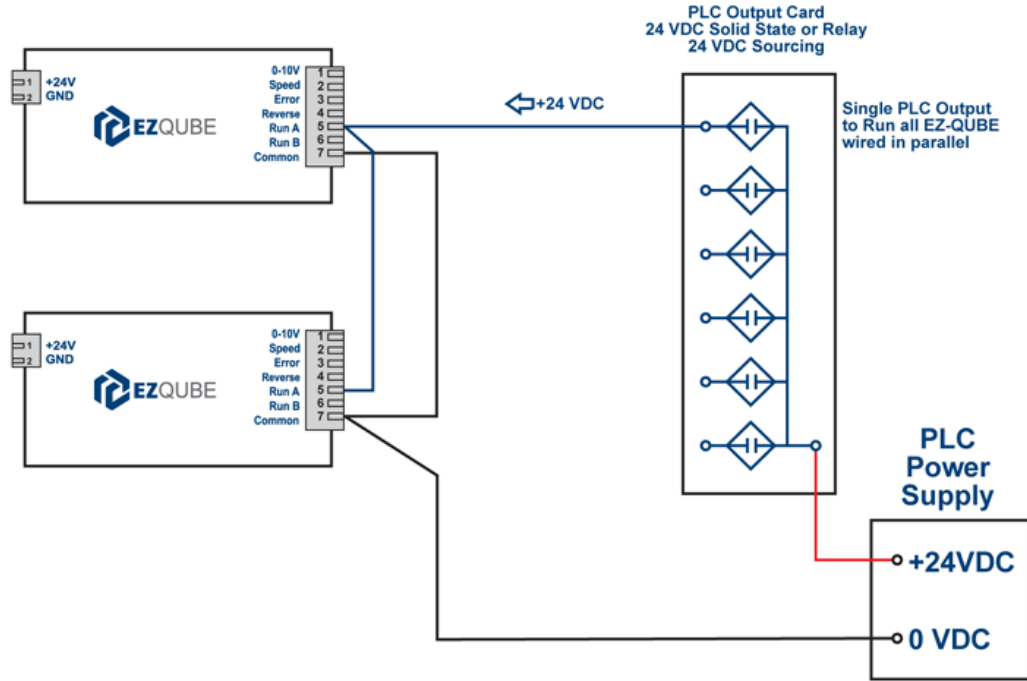

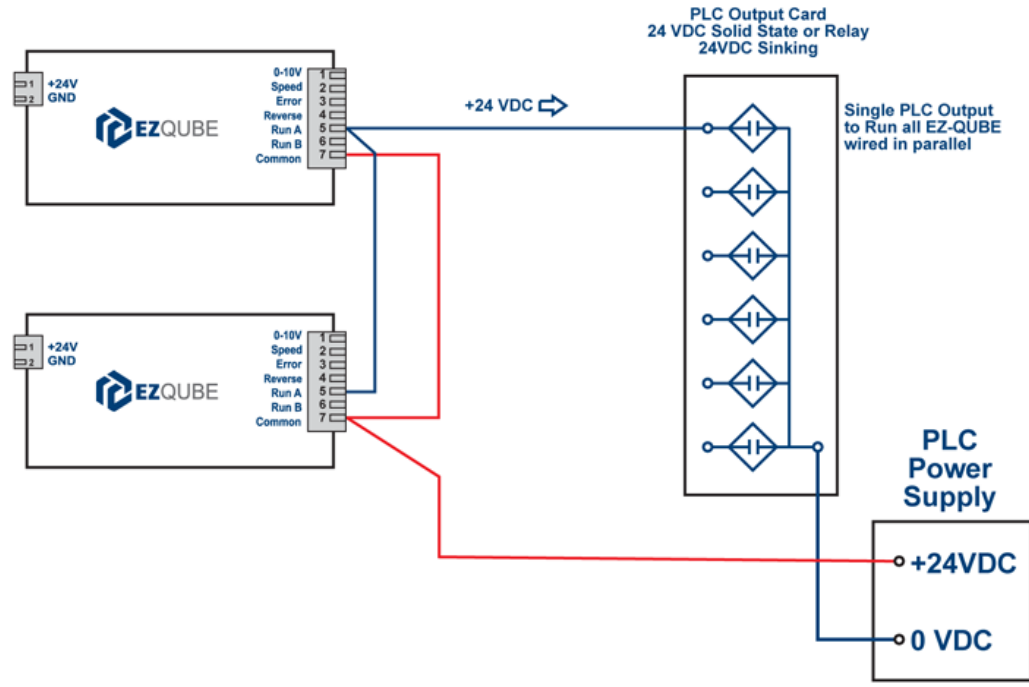

# Wiring Multiple Modules with Single Signal for EZ-QUBE-P- J Article Number 1510-6040

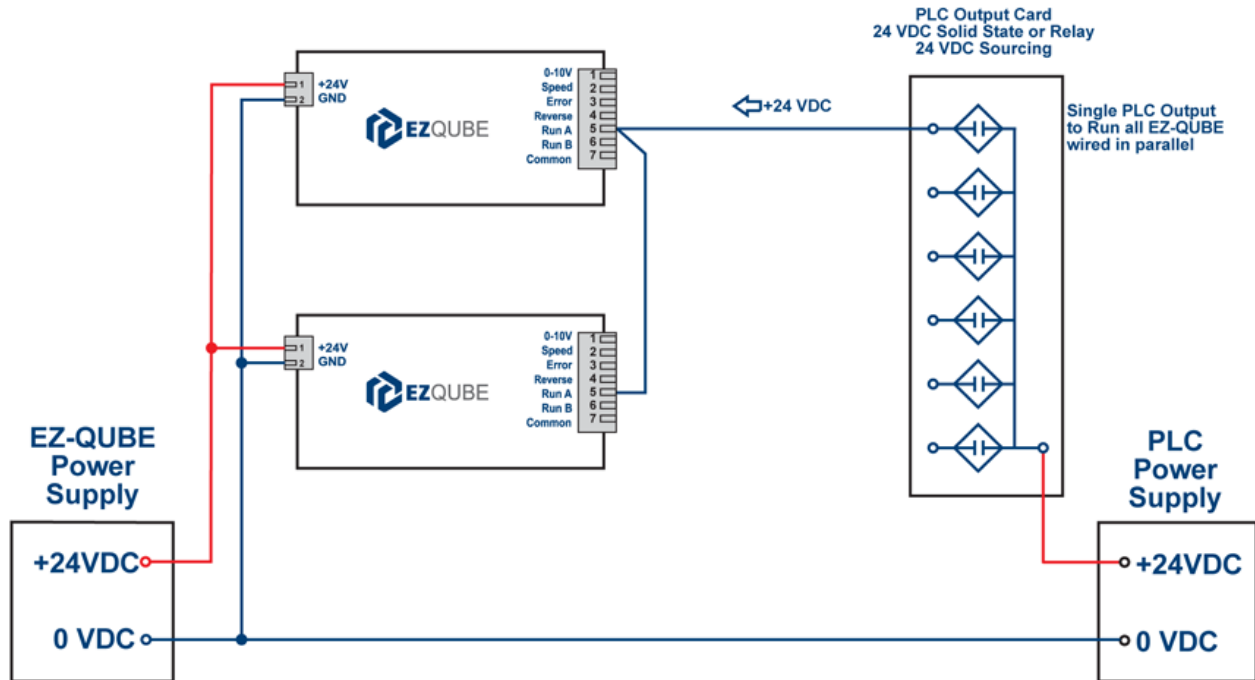

## 4.3.3. Multiple Modules from Individual Signals

---

# Wiring Multiple Modules with Individual Signals (all models EXCEPT EZ-QUBE-P-J Article Number 1510-6040)

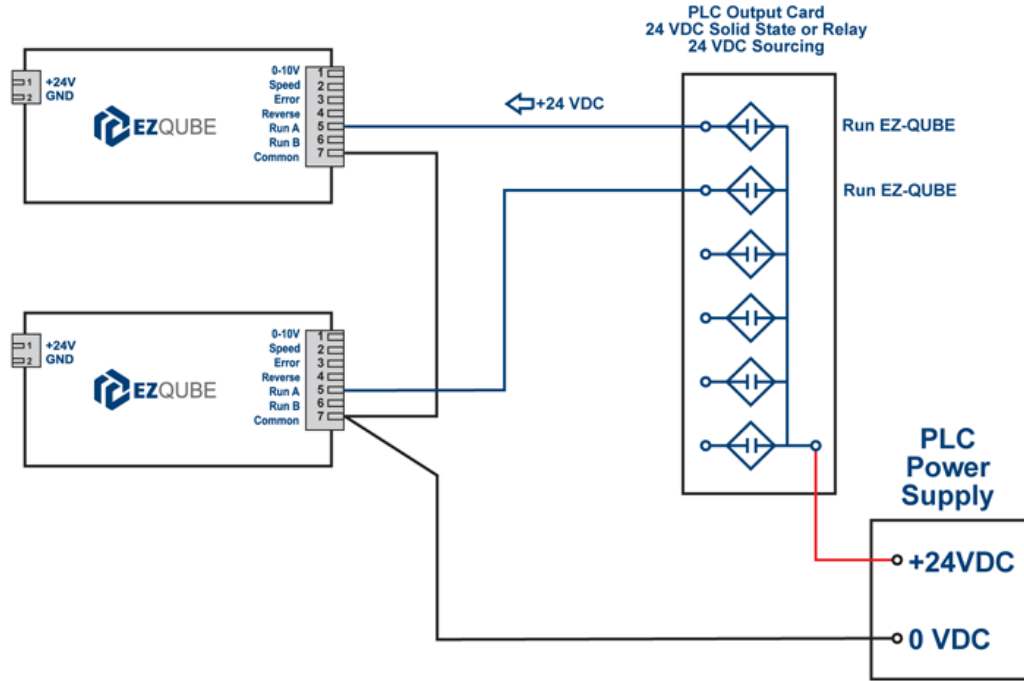

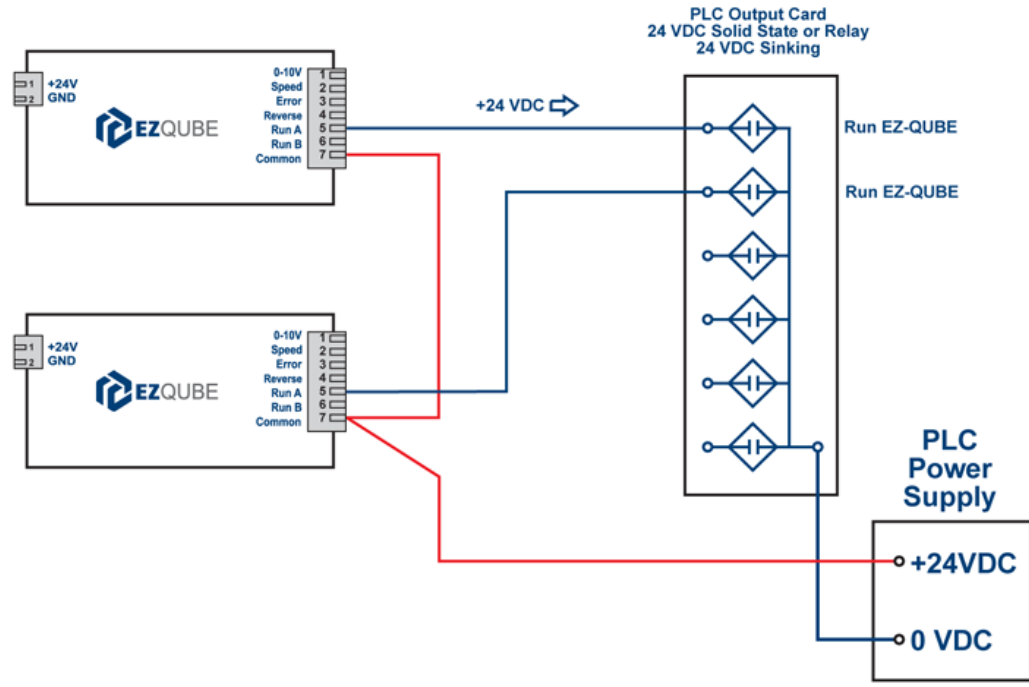

!

## Wiring Multiple Modules with Individual Signals for EZ-QUBE-P-J Article Number 1510-6040

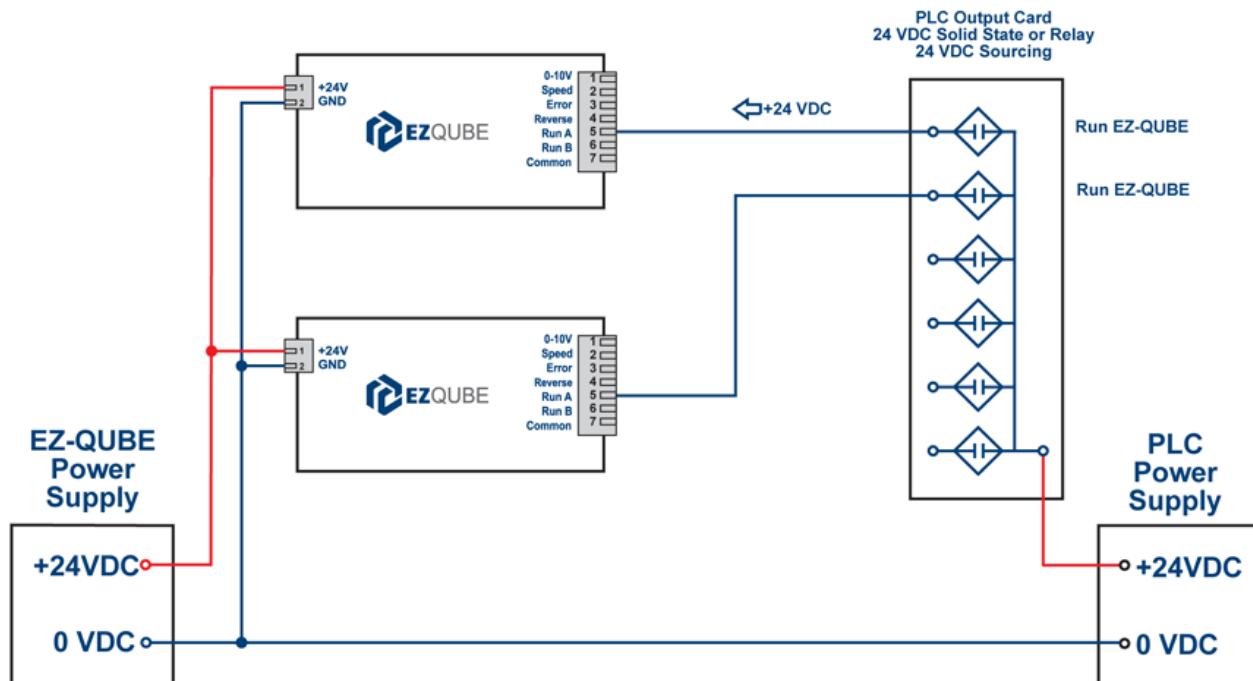

### 4.4. 0-10V Analog Input

\* The Speed DIP Switches 1 thru 5 must be properly set for *Analog Speed Control*

\* Please Note: Analog control STILL requires RUN/REVERSE signal(s). Wiring for these are not shown on these diagrams for clarity.

! Analog signal is always referenced to the module's 0V GND and NOT the module's COMMON terminal

## Analog Source Input



## Analog Potentiometer

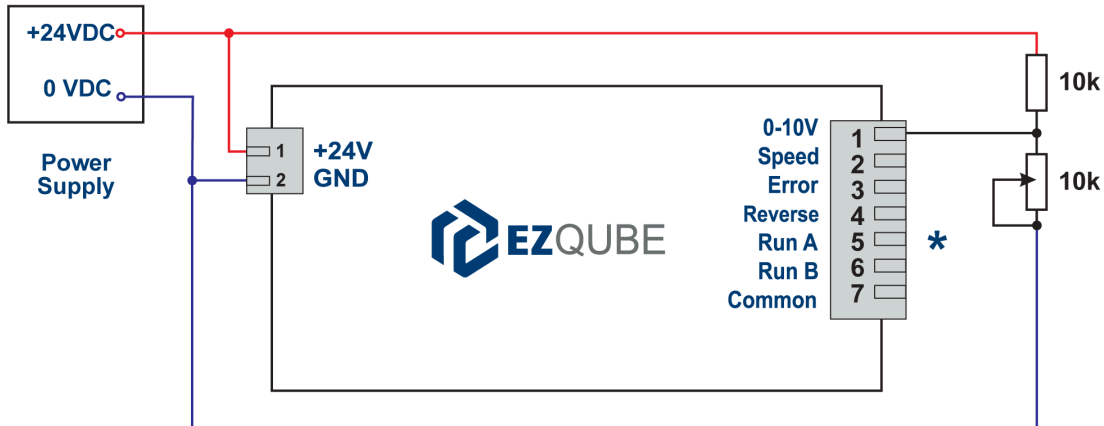

## Analog Potentiometer with Minimum Speed Divider

A voltage dividing resistor circuit can be used so that when the potentiometer is set to 0, there is a non-zero minimum speed for the motor when a RUN signal is applied.

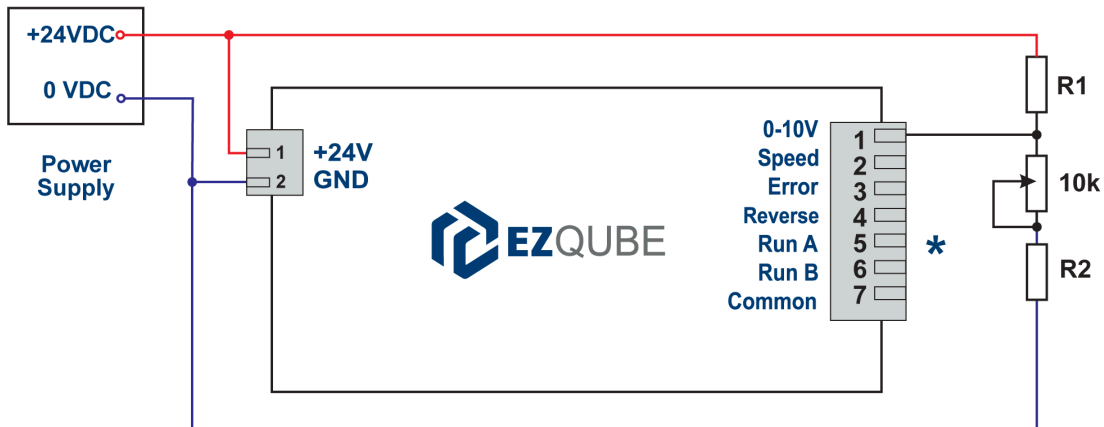

Here are some resistor values to get some common minimum speeds when the potentiometer is set to 0:

R1 (Ohms)	R2 (Ohms)	Minimum Speed
18k	820	10%
18k	1.6k	20%
18k	2.6k	30%
18k	3.6k	40%

## 4.5. Error Output

The *Error Output* provides a digital signal to indicate various error conditions. This signal coupled with the *Error LED* provides troubleshooting information about the module.

Click [HERE](#) for more information about LED states and the various conditions that affect the *Error Output* signal.

[Error Output Wiring for PNP Versions](#)

[Error Output Wiring for NPN Versions](#)



## 4.5.1. PNP Versions

Wiring Diagrams for the following modules:

EZ-QUBE-P – Article Number 1510-6000

EZ-QUBE-P-MR – Article Number 1510-6020

EZ-QUBE-P-J – Article Number 1510-6040

EZ-QUBE-HTBF-P – Article Number 1510-4110

### Single PNP Module Wiring



### Wiring Multiple PNP Modules in Parallel to Single Input

- \* In this wiring scheme, ANY of the EZ-QUBE *ERROR* signals will energize the PLC input. Also, if more than one EZ-QUBE module has energized its *ERROR* signal, the PLC input will be energized.

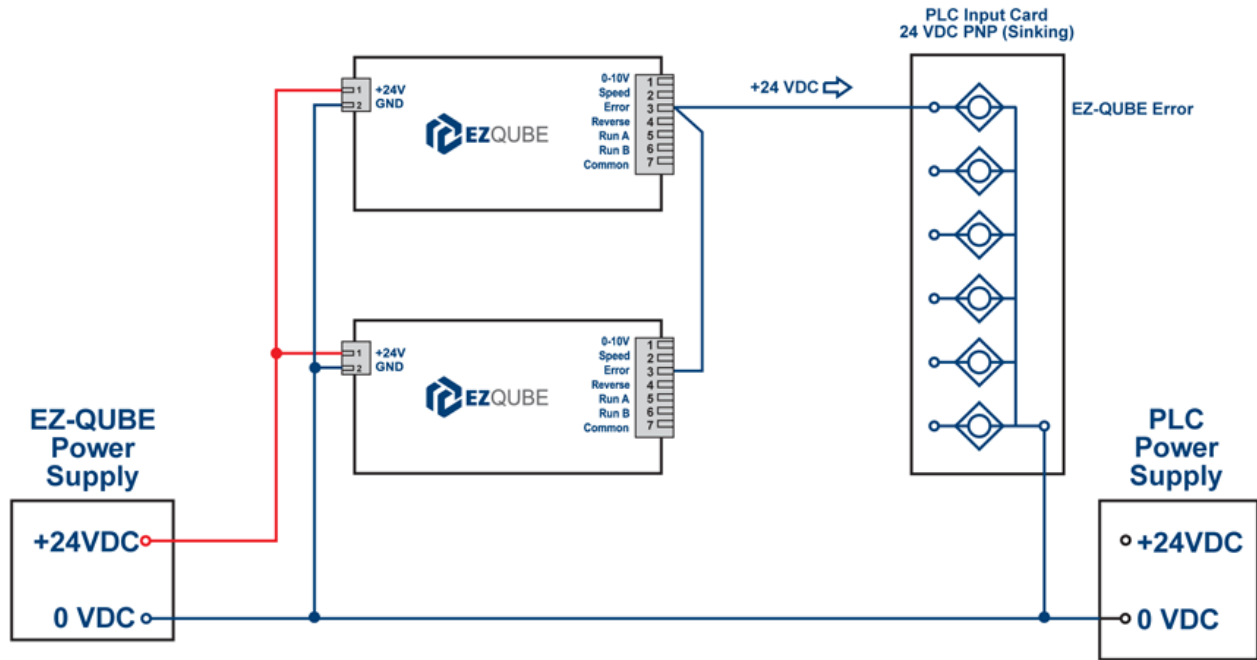

# Wiring Multiple PNP Modules to Individual Inputs

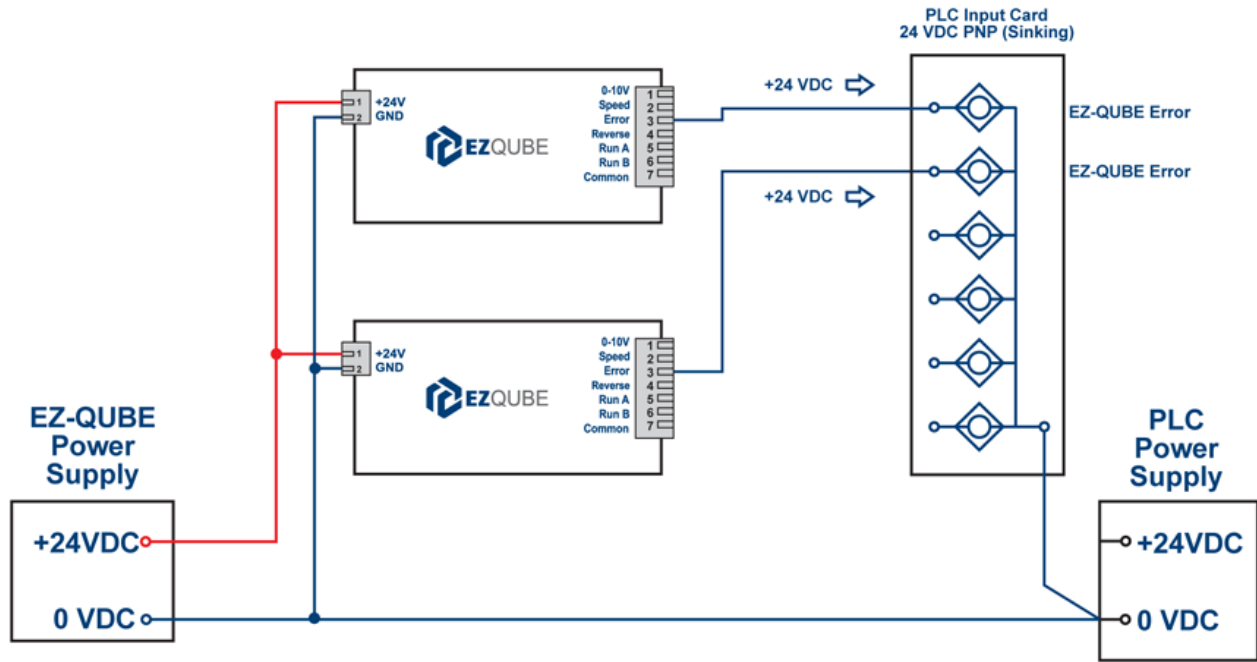

## 4.5.2. NPN Versions

Wiring Diagrams for the following modules:

EZ-QUBE-N – Article Number 1510-5000

EZ-QUBE-HTBF-N – Article Number 1510-4120

### Single NPN Module Wiring



### Wiring Multiple NPN Modules in Parallel to Single Input

- \* In this wiring scheme, ANY of the EZ-QUBE *ERROR* signals will energize the PLC input. Also, if more than one EZ-QUBE module has energized its *ERROR* signal, the PLC input will be energized.

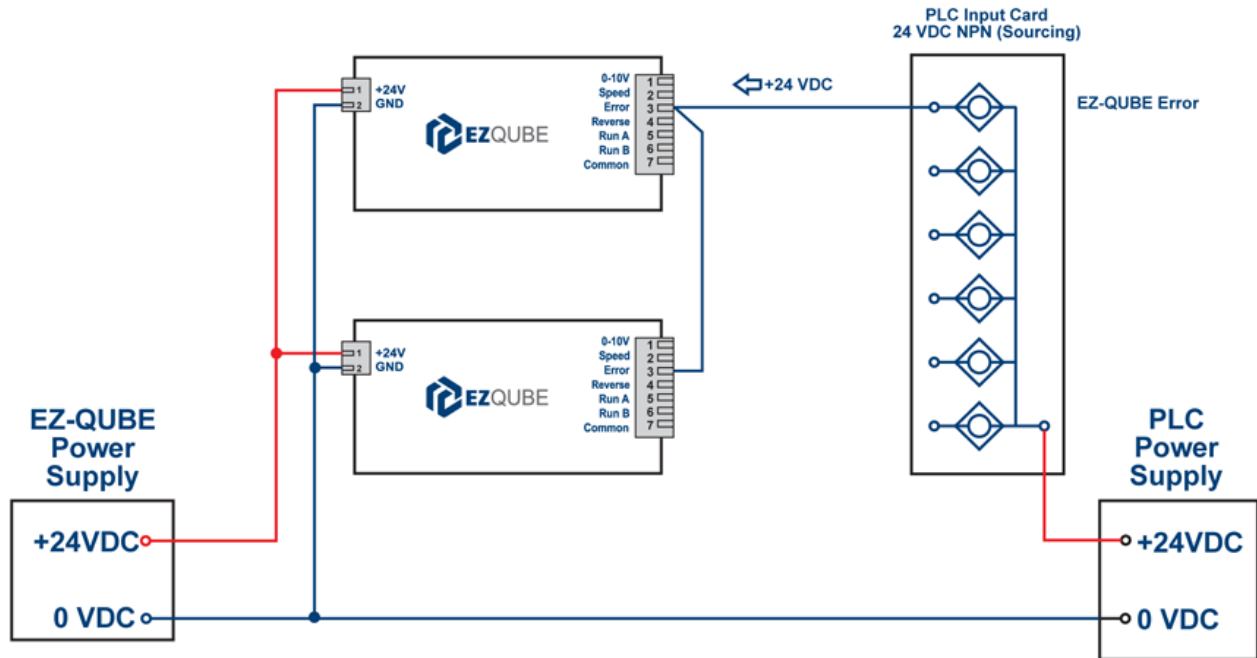

## Wiring Multiple NPN Modules to Individual Inputs

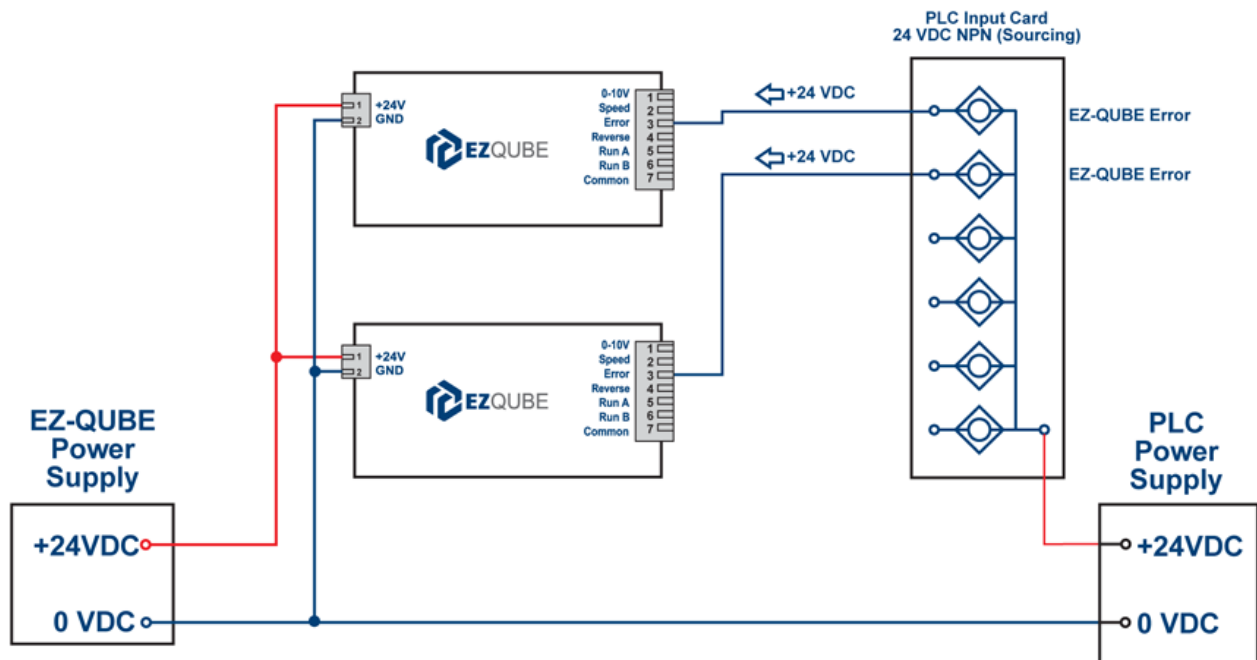

## 4.6. Speed Output

---

The *Speed Output* provides a pulse signal proportional to the running speed of the motor. This frequency is different between *Eco* and the *Boost* modes.

[Click here to see a list of motor speed settings and their corresponding Speed Out frequencies](#)

[Wiring for PNP Versions](#)

[Wiring for NPN Versions](#)

### 4.6.1. PNP Versions

---

Wiring Diagrams for the following modules:

EZ-QUBE-P – Article Number 1510-6000

EZ-QUBE-P-MR – Article Number 1510-6020

EZ-QUBE-P-J – Article Number 1510-6040

EZ-QUBE-HTBF-P – Article Number 1510-4110



Please note for part number [EZ-QUBE-P-MR \(Article Number 1510-6020\)](#) the Speed output is not a frequency signal but is a maintained digital output signal that is energized whenever the motor is running

# Single PNP Module Wiring



# Wiring Multiple PNP Modules in Parallel

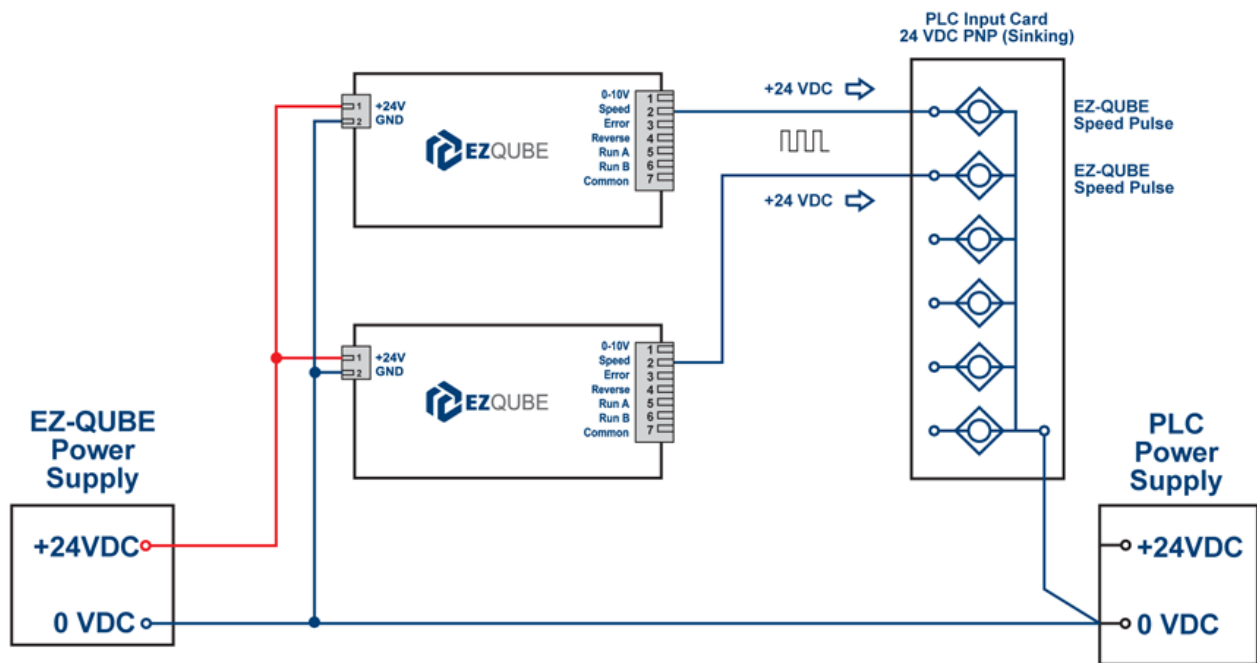

## 4.6.2. NPN Versions

Wiring Diagrams for the following modules:

EZ-QUBE-N – Article Number 1510-5000

EZ-QUBE-HTBF-N – Article Number 1510-4120

### Single NPN Module Wiring







## 5. DIP Switch Settings

Each EZ-QUBE module has three DIP Switches designated as *SPEED*, *CONFIG* and *ACC/DEC*

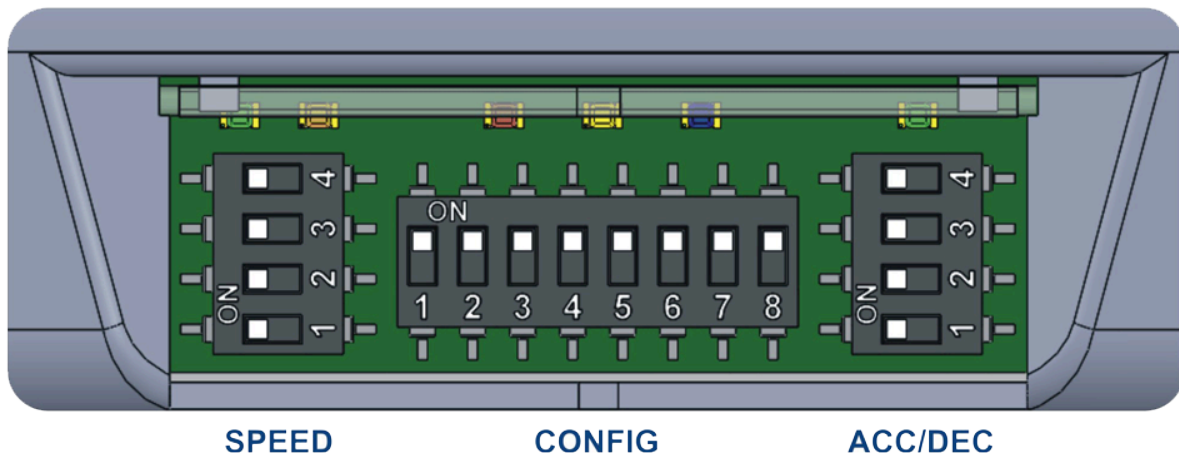

\* Please note that all switch actions take effect immediately except Switch CONFIG- 2 “Direction of Rotation”. It will take effect only when the motor is NOT running.

### ON/OFF Switch Position

The DIP Switch and LED area on the EZ-QUBE module utilizes a hinged clear plastic protective cover. Simply lift the cover from the bottom edge of the module to open the cover to gain access to the DIP Switches. Be sure to snap the cover back closed when done making and changes to the DIP Switch settings.

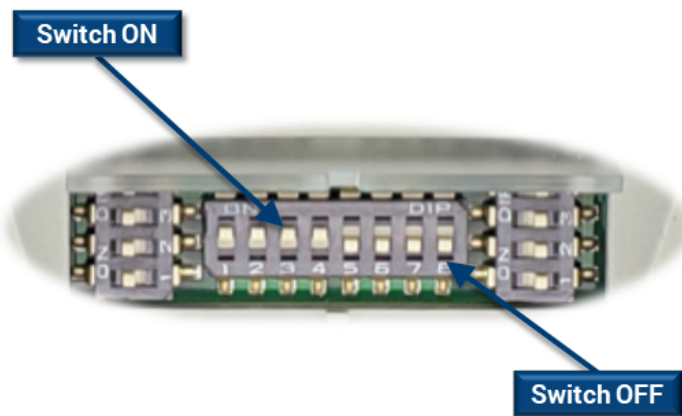

## Motor Rotation Definition

The EZ-QUBE uses a *Clock-Wise (CW)* and *Counter Clock-Wise (CCW)* motor rotation definition. The reference for this distinction is based upon viewing the MDR from the cable exit end of the roller.

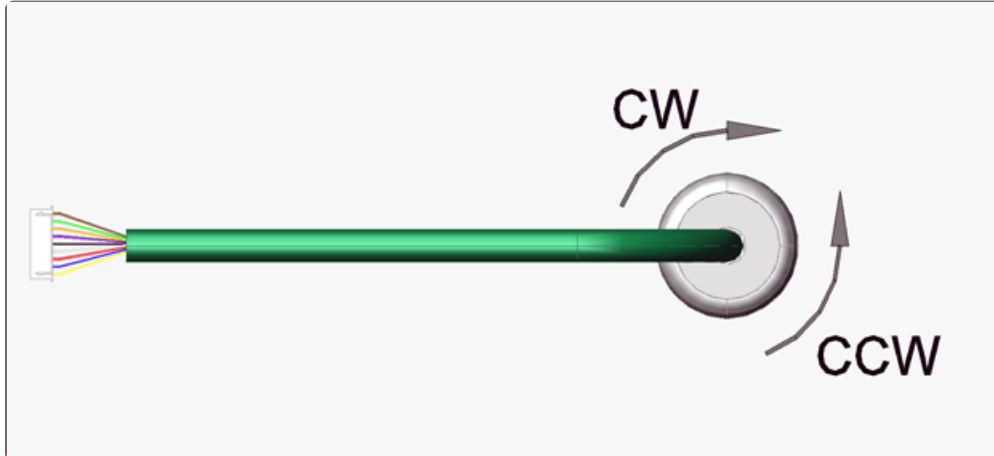

[CONFIG DIP Switch Settings](#)

[SPEED DIP Switch Settings](#)

[ACC/DEC DIP Switch Settings](#)

## 5.1. CONFIG DIP Switch

---

For EZ-Qube-N, -P, -P-MR, -P-J (8 Switch Positions)

Switch	Function	OFF	ON
1	Speed Range Selection	Low Range	High Range
2	Direction of Rotation	CCW	CW
3	Open / Closed Loop Speed Control	Open Loop	Closed Loop
4	Auto / Manual Error Reset	Manual Reset	Automatic Reset

5	Motor Performance Selection	ECO Mode*	Boost Mode*
6	Holding Brake Selection	<a href="#">Refer to Electronic Holding Brake Settings</a>	
7			
8	Deceleration Time Adjustment	Decel Time = Accel Time	Decel Time = 2 X Accel Time

[\\*Refer to Motor Performance Settings for definition of these modes](#)

## For EZ-Qube-HTBF-P, -N (9 Switch Positions)

Switch	Function	OFF	ON
1	Speed Range Selection	Low Range	High Range
2	Direction of Rotation	CCW	CW
3	Open / Closed Loop Speed Control	Open Loop	Closed Loop
4	Auto / Manual Error Reset	Manual Reset	Automatic Reset
5	Motor Performance Selection	<a href="#">Refer to Motor Performance Settings</a>	
6			
7	Holding Brake Selection	<a href="#">Refer to Electronic Holding Brake Settings</a>	
8			
9	Deceleration Time Adjustment	Decel Time = Accel Time	Decel Time = 2 X Accel Time

## 5.1.1. Electronic Holding Brake Settings

\* The EZ-QUBE module uses its motor power circuits to decelerate the motor per the Accel/Decel DIP Switch settings. Once the motor has finished its controlled deceleration, then it applies one of these 3 Electronic Holding Brake options in which to provide various levels of holding brake force or resistance. The Electronic Holding Brake function IS NOT used to slow down the motor

### Electronic Holding Brake Definitions

Method	Description
Normal	Standard Dynamic Shunt Coil - Each of the 3 Motor power transistor circuits in the EZ-QUBE are internally shunted to ground after the module has performed its configured deceleration function. The mechanical inertia of the gearbox and the magnetic resistance of the motor rotor provides the holding force. This is the MDR industry standard holding braking method
Free	Free Spin - Each of the 3 Motor power transistor circuits in the EZ-QUBE are internally opened after the module has performed its configured deceleration function. The mechanical inertia of the gearbox provides the only holding force
Servo Brake	Active Servo - When the EZ-QUBE module has performed its configured deceleration function, it remembers the position of the motor rotor and provides active power to the motor coils to maintain that roller position

### Electronic Holding Brake Selection DIP Switch Settings

Electronic Holding Brake Method	Switch 6	Switch 7
Normal	OFF	OFF
Free	ON	OFF
Servo Brake	OFF	ON

## Mechanical Holding Brake Option

Some Pulseroller MDR's and PGD's are available with an option for a *mechanical holding brake*. Please note this is separate and not related to the *Electronic Holding Brake* functionality.

! Please note that ONLY EZ-QUBE-HTBF-P, -N models provide release control for a mechanical holding brake

! For EZ-QUBE-HTBF-P, -N DO NOT use Servo Electronic Brake Method when you have a mechanical holding brake because this may overheat and damage the MDR or PDG unit.

### 5.1.2. Motor Performance Settings

Motor Performance Setting	Rated Current	Starting Current	Starting Current Duration	Application
ECO	2.5A	3A	5 sec.	General purpose use, maximum speed of MDR is available
BOOST	3.5A	5A	1.5 sec.	Heavier load, maximum speed of MDR is reduced
BOOST 8 EZ-QUBE-HTBF-P, -N Only	3.5A	8A	1.5 sec.	Starting heavier load from stop, maximum speed of MDR is reduced
PDU MAX EZ-QUBE-HTBF-P, -N Only	8A	-	no limit	Only for use with PDU-90 Lift/Lower MDRs, allows 6400 motor RPM

! PDU MAX setting is not to be used for continuous or medium to high duty cycle applications. The MDR and/or EZ-QUBE-HTBF will overheat and potentially fail. PDU-MAX setting is designed for a very brief burst of starting torque such as to raise a transfer unit with a load on it and a comparatively long OFF duration to allow for MDR/module cooling.

## DIP Switch settings for EZ-QUBE-HTBF-P, -N

Motor Performance	Switch 5	Switch 6
ECO	OFF	OFF
BOOST	ON	OFF
BOOST 8	OFF	ON
PDU MAX	ON	ON

\* ECO and BOOST as defined here also applies to all EZ-QUBE models

## 5.2. SPEED DIP Switch

The *SPEED DIP* Switch works in conjunction with the *CONFIG DIP* Switch #1. *CONFIG DIP* Switch #1 switches between the high speed range and the low speed range.

No.	CONFIG SW 1	SPEED SW 4	SPEED SW 3	SPEED SW 2	SPEED SW 1	ECO Mode Motor RPM	BOOST Mode Motor RPM	ECO/BOOST PWM %	ECO Mode Speed Out Hz	BOOST Mode Speed Out Hz
1	OFF	OFF	OFF	OFF	OFF	0-10V Analog				
2	OFF	OFF	OFF	OFF	ON	580	580	25.00%	24.2	24.2
3	OFF	OFF	OFF	ON	OFF	800	800	27.50%	33.3	33.3
4	OFF	OFF	OFF	ON	ON	1000	1000	30.00%	41.7	41.7
5	OFF	OFF	ON	OFF	OFF	1200	1200	32.50%	50.0	50.0
6	OFF	OFF	ON	OFF	ON	1400	1400	35.00%	58.3	58.3
7	OFF	OFF	ON	ON	OFF	1600	1600	37.50%	66.7	66.7
8	OFF	OFF	ON	ON	ON	1800	1800	40.00%	75.0	75.0
9	OFF	ON	OFF	OFF	OFF	2000	1900	42.50%	83.3	79.2
10	OFF	ON	OFF	OFF	ON	2200	2000	45.00%	91.7	83.3
11	OFF	ON	OFF	ON	OFF	2400	2100	47.50%	100.0	87.5

12	OFF	ON	OFF	ON	ON	2600	2200	50.00%	108.3	91.7
13	OFF	ON	ON	OFF	OFF	2800	2300	52.50%	116.7	95.8
14	OFF	ON	ON	OFF	ON	3000	2400	55.00%	125.0	100.0
15	OFF	ON	ON	ON	OFF	3200	2500	57.50%	133.3	104.2
16	OFF	ON	ON	ON	ON	3400	2600	60.00%	141.7	108.3
17	ON	OFF	OFF	OFF	OFF	3600	2700	62.50%	150.0	112.5
18	ON	OFF	OFF	OFF	ON	3800	2800	65.00%	158.3	116.7
19	ON	OFF	OFF	ON	OFF	4000	2900	67.50%	166.7	120.8
20	ON	OFF	OFF	ON	ON	4200	3000	70.00%	175.0	125.0
21	ON	OFF	ON	OFF	OFF	4400	3100	72.50%	183.3	129.2
22	ON	OFF	ON	OFF	ON	4600	3200	75.00%	191.7	133.3
23	ON	OFF	ON	ON	OFF	4800	3300	77.50%	200.0	137.5
24	ON	OFF	ON	ON	ON	5000	3400	80.00%	208.3	141.7
25	ON	ON	OFF	OFF	OFF	5100	3500	82.50%	212.5	145.8
26	ON	ON	OFF	OFF	ON	5200	3600	85.00%	216.7	150.0
27	ON	ON	OFF	ON	OFF	5300	3700	87.50%	220.8	154.2
28	ON	ON	OFF	ON	ON	5400	3800	90.00%	225.0	158.3
29	ON	ON	ON	OFF	OFF	5500	3900	92.50%	229.2	162.5
30	ON	ON	ON	OFF	ON	5600	4000	95.00%	233.3	166.7
31	ON	ON	ON	ON	OFF	5700	4100	97.50%	237.5	170.8
32	ON	ON	ON	ON	ON	5800	4200	100.00%	242.0	175.0

## 5.2.1. 0-10V Analog Speed

The relationship between the external voltage at input 0-10V and the motor speed is linear in the range of the minimum and maximum speeds of the MDR (580 – 5800) RPM for ECO and (580 – 4200) RPM for BOOST Mode. The table below shows the 22 sample values at equal intervals.



Please note that for EZ-QUBE-HTBF-P, -N, the values shown for BOOST mode are



the same for BOOST 8 mode

No.	0-10V Input	ECO Mode Motor RPM	BOOST Mode Motor RPM	Open Loop PWM %
1	0.00 V	580	580	10.00%
2	0.50 V	580	580	10.00%
3	1.00 V	580	580	10.00%
4	1.50 V	870	630	15.00%
5	2.00 V	1160	840	20.00%
6	2.50 V	1450	1050	25.00%
7	3.00 V	1740	1260	30.00%
8	3.50 V	2030	1470	35.00%
9	4.00 V	2320	1680	40.00%
10	4.50 V	2610	1890	45.00%
11	5.00 V	2900	2100	50.00%
12	5.50 V	3190	2310	55.00%
13	6.00 V	3480	2520	60.00%
14	6.50 V	3770	2730	65.00%
15	7.00 V	4060	2940	70.00%
16	7.50 V	4350	3150	75.00%
17	8.00 V	4640	3360	80.00%
18	8.50 V	4930	3570	85.00%
19	9.00 V	5220	3780	90.00%
20	9.50 V	5510	3990	95.00%
21	10.00 V	5800	4200	100.00%
22	11.00 V	5800	4200	100.00%

## 5.2.2. Speed Calculation

To determine the speed of the roller, you must know the diameter of your roller tube and the gear reduction ratio of the motor roller in order to calculate the speed based upon the Motor RPM you have selected with SPEED DIP Switches 1 thru 4 and CONFIG DIP Switch 1.

### Speed Code and Gear Ratio Table

The *Speed Code* and *Tube Diameter* for any Pulseroller are each 2 digit numbers found on the label at the cable end of the unit.

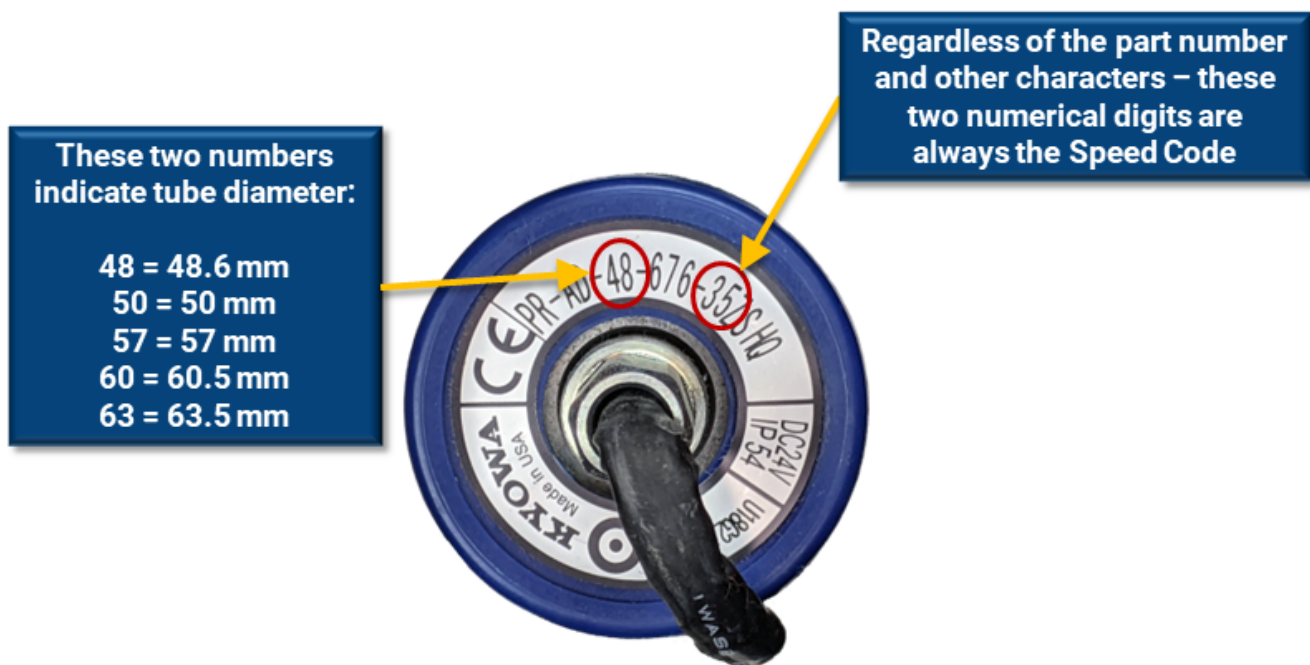

Once you know your *Speed Code*, you can then reference these charts to get the corresponding *Gear Ratio*

Speed Code	Gear Reduction Ratio
10	66.978 : 1
15	45 : 1
20	32.94 : 1
25	27 : 1

35	18.3 : 1
45	15 : 1
60	10.98 : 1
75	9 : 1
95	6.818 : 1
125	5 : 1
175	3.66 : 1
215	3 : 1

The formula for calculating the speed in m/s is:

$$\text{Speed (in meters/second)} = \left[ \frac{\text{Motor RPM}}{\text{Gear Reduction}} \right] \times \pi \times \left[ \frac{\text{Tube Diameter (in meters)}}{60} \right]$$

For example, for a 75 speed code roller with a 50 mm tube diameter running at 5000 RPM the calculation is:

$$\text{Speed} = \frac{5000}{9} \times \pi \times \frac{0.05}{60} = 1.45 \text{ Meters/sec}$$

## 5.3. ACC/DEC DIP Switch

These switches are used to select the acceleration and deceleration *G force* the control uses when starting and stopping the motor respectively. The EZ-QUBE acceleration/deceleration control is designed to provide a *constant G force or ramp slope* regardless of the speed setting for a given SPEED DIP switch setting. The selections made on the ACC/DEC DIP switches set both the acceleration and deceleration G force to the same value when CONFIG DIP Switch 8 is OFF. When CONFIG DIP Switch 8 is ON, the deceleration value is 2X the acceleration value.

✿ The actual expected time elapsed for a given ramp selection is dependent on the motor RPM selected

[Settings for Equal Accel/Decel Ramps \(CONFIG DIP Switch 8 = OFF\)](#)

[Settings for Decel Ramp Equal 2 X Accel Ramp \(CONFIG DIP Switch 8 = ON\)](#)

## 5.3.1. Accel/Decel Equal

When CONFIG DIP Switch 8 is OFF, then the acceleration and deceleration ramps are **equal**.

The following chart shows the 16 possible ACC/DEC DIP switch settings for *G force ramp* and the expected ramp *time* to reach full speed (when accelerating) or to stop (when decelerating) when the motor speed is set to *maximum* (Switch setting item 32 from the [SPEED DIP Switch chart](#)) regardless of ECO or BOOST modes.

Accel/Decel Times when SPEED setting is 100% maximum					
ACC/DEC SW 4	ACC/DEC SW 3	ACC/DEC SW 2	ACC/DEC SW 1	Acceleration Time (sec)	Deceleration Time (sec) CONFIG SW 8 OFF
OFF	OFF	OFF	OFF	0.050	0.050
OFF	OFF	OFF	ON	0.100	0.100
OFF	OFF	ON	OFF	0.200	0.200
OFF	OFF	ON	ON	0.300	0.300
OFF	ON	OFF	OFF	0.400	0.400
OFF	ON	OFF	ON	0.500	0.500
OFF	ON	ON	OFF	0.600	0.600
OFF	ON	ON	ON	0.700	0.700
ON	OFF	OFF	OFF	0.800	0.800
ON	OFF	OFF	ON	1.000	1.000
ON	OFF	ON	OFF	1.200	1.200
ON	OFF	ON	ON	1.400	1.400
ON	ON	OFF	OFF	1.600	1.600
ON	ON	OFF	ON	1.800	1.800
ON	ON	ON	OFF	2.000	2.000
ON	ON	ON	ON	2.500	2.500

## Example with Graph

We have 2 motors, Motor #1 is set to 100% speed and Motor #2 is set to 50% speed. If we set the ACC/DEC DIP Switches 4 thru 1 to ON, ON ,ON, OFF we can see from the chart that we should have a 2.000 second acceleration time and a 2.00 deceleration time when our speed is set to 100% maximum. Because the Accel/Decel ramps are the same, if our speed is at 50% of maximum, then our acceleration and deceleration times would be 1/2 of maximum, thus 1.000 seconds for each. In our example, we start both motors at the same time and let them run for 6 seconds and then stop both at the same time. This is shown in the following graph:

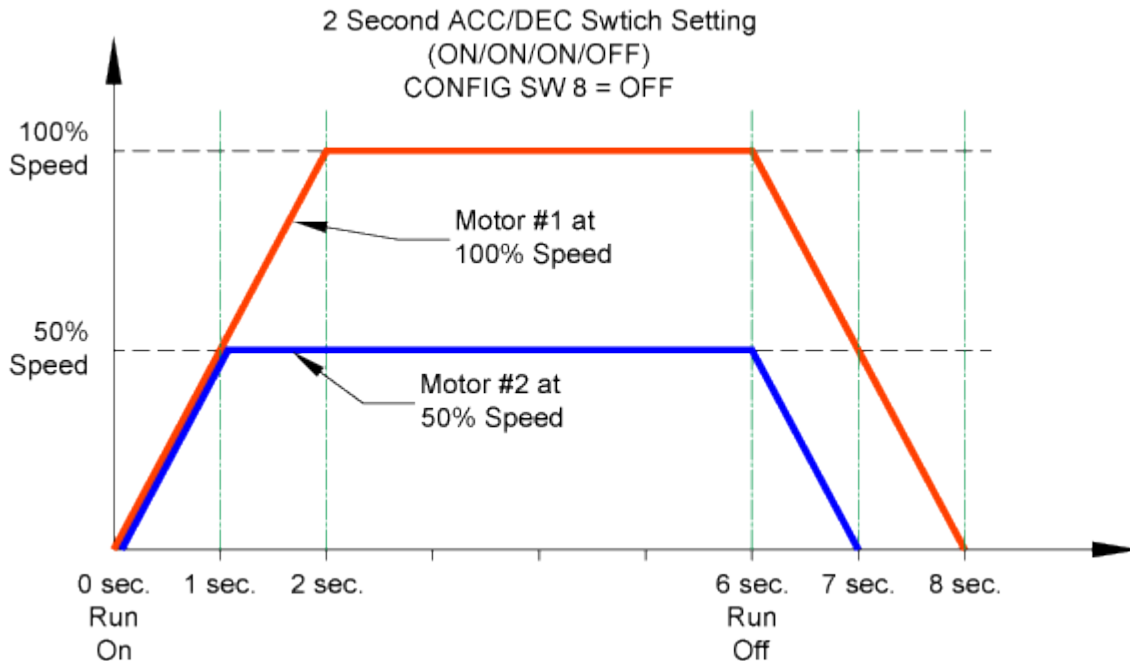

### 5.3.2. Decel Equal 2 x Accel

When CONFIG DIP Switch 8 is ON, then the deceleration ramp is equal to twice (2X) the acceleration ramps.

The following chart shows the 16 possible ACC/DEC DIP switch settings for *G force ramp* and the expected ramp *time* to reach full speed (when accelerating) or to stop (when decelerating) when the motor speed is set to *maximum* (Switch setting item 32 from the [SPEED DIP Switch chart](#)) regardless of ECO or BOOST modes.

Accel/Decel Times when SPEED setting is 100% maximum					
ACC/DEC SW 4	ACC/DEC SW 3	ACC/DEC SW 2	ACC/DEC SW 1	Acceleration Time (sec)	Deceleration Time (sec) CONFIG SW 8 ON

OFF	OFF	OFF	OFF	0.050	0.100
OFF	OFF	OFF	ON	0.100	0.200
OFF	OFF	ON	OFF	0.200	0.400
OFF	OFF	ON	ON	0.300	0.600
OFF	ON	OFF	OFF	0.400	0.800
OFF	ON	OFF	ON	0.500	1.000
OFF	ON	ON	OFF	0.600	1.200
OFF	ON	ON	ON	0.700	1.400
ON	OFF	OFF	OFF	0.800	1.600
ON	OFF	OFF	ON	1.000	2.000
ON	OFF	ON	OFF	1.200	2.400
ON	OFF	ON	ON	1.400	2.800
ON	ON	OFF	OFF	1.600	3.200
ON	ON	OFF	ON	1.800	3.600
ON	ON	ON	OFF	2.000	4.000
ON	ON	ON	ON	2.500	5.000

## Example with Graph

We have 2 motors, Motor #1 is set to 100% speed and Motor #2 is set to 50% speed. If we set the ACC/DEC DIP Switches 4 thru 1 to ON, ON, ON, OFF we can see from the chart that we should have a 2.000 second acceleration time and a 4.00 deceleration time when our speed is set to 100% maximum. Because the Accel/Decel ramps are the same, if our speed is at 50% of maximum, then our acceleration and deceleration times would be 1/2 of maximum, thus 1.000 seconds for acceleration and 2.000 seconds for deceleration. In our example, we start both motors at the same time and let them run for 6 seconds and then stop both at the same time. This is shown in the following graph:

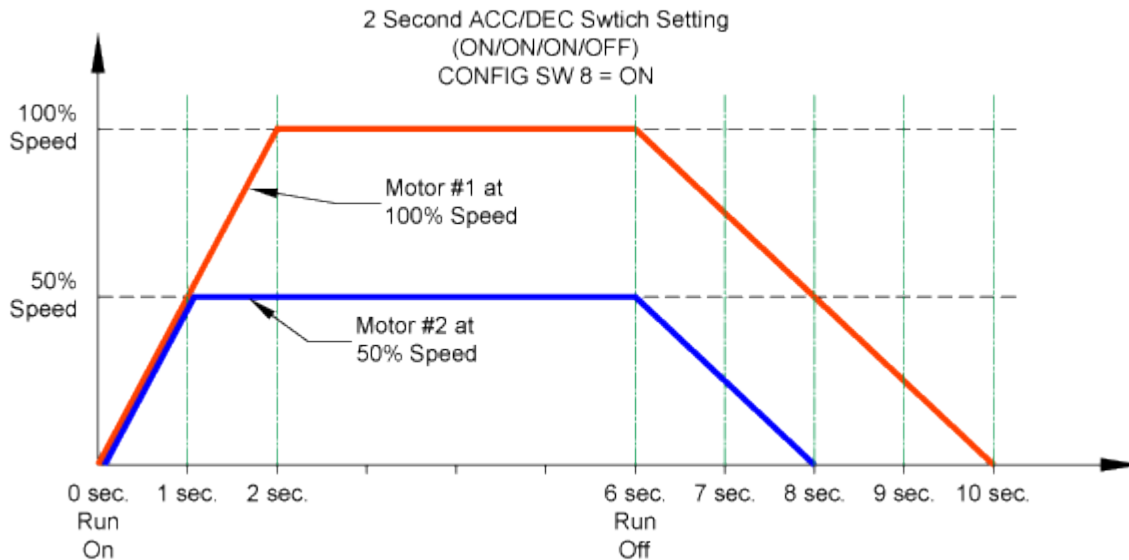

### 5.3.3. Accel/Decel Time Formula

To find the Acceleration/Deceleration times for speed settings other than 100%, the following simple formula can be used to calculate the value:

$$T = \left( \frac{\text{Speed}}{\text{Max RPM}} \right) \times T_{Max}$$

Where:

- $T$  = New Ramp Up/Down time
- $Speed$  = New Speed in RPM from CONFIG SW 1 / SPEED SW 1 thru 4
- $Max\ RPM$  = 5800 for ECO Mode or 4200 for BOOST mode
- $T_{Max}$  = Time value from ACC/DEC chart

### Example

For example, let's say we have selected the CONFIG and SPEED DIP switches for the 4000 RPM setting:

CONFIG SW 1 = ON

SPEED SW 4 thru 1 = OFF/OFF/ON/OFF

And we have selected ACC/DEC DIP switches for the 1.200 second setting:

ACC/DEC SW 4 thru 1 = ON/OFF/ON/OFF

Assuming we are in ECO Mode, our formula looks like:

$$T = \left( \frac{4000}{5800} \right) \times 1.2 = 0.828 \text{ sec}$$



## 6. Operation

The combination of signals on the *Run A* and *Run B* terminals allows you to dynamically set the speed with your digital run signals to the EZ-QUBE module. The following chart lists the signal states and their respective speed control:

Run A	Run B	Description
ON	OFF	Start motor and run at 100% of the speed selected on DIP Switches or "0-10V" input
ON	ON	Start motor and run at 75% of the speed selected on DIP Switches or "0-10V" input
OFF	ON	Start motor and run at 50% of the speed selected on DIP Switches or "0-10V" input
OFF	OFF	Stop motor

! Please note that Run A and Run B signals apply to the 0-10V Analog Speed input and will result in speeds that are 100%, 75%, and 50% of the analog signal

# 7. Output Signals & LED Indicators

---

The EZ-QUBE module utilizes 2 output signals: *SPEED* and *ERROR*.

## SPEED Signal

- For all EZ-QUBE modules except EZ-QUBE-P-MR (Article Number 1510-6020), the *SPEED* output produces an oscillating signal whose frequency is proportional to the speed of the motor.
- For the EZ-QUBE-P-MR (Article Number 1510-6020) module, the *SPEED* output is a non-oscillating digital signal that is energized when the motor is running and de-energized when the motor is stopped.

### [How to Wire the \*SPEED\* signal](#)

[Click here to see a list of motor speed settings and their corresponding \*Speed Out\* frequencies](#)

[Click here for the definition of the \*SPEED\* Output](#)

## ERROR Signal

The *ERROR* signal is a digital output that is used in conjunction with the *LED Status Indicators* to display specific conditions of the module. In general, when any one of several error conditions is active, the *ERROR* signal will be ON. If no error condition exists, then the *ERROR* signal will be OFF

### [How to Wire the \*ERROR\* signal](#)

[Click here to see Error Output states and LED Status](#)

## 7.1. Pulse Speed Output

---

The *SPEED* output on the Removable I/O Terminal Block provides a pulsed signal whose frequency is proportional to the motor's running speed. This relationship is shown below.

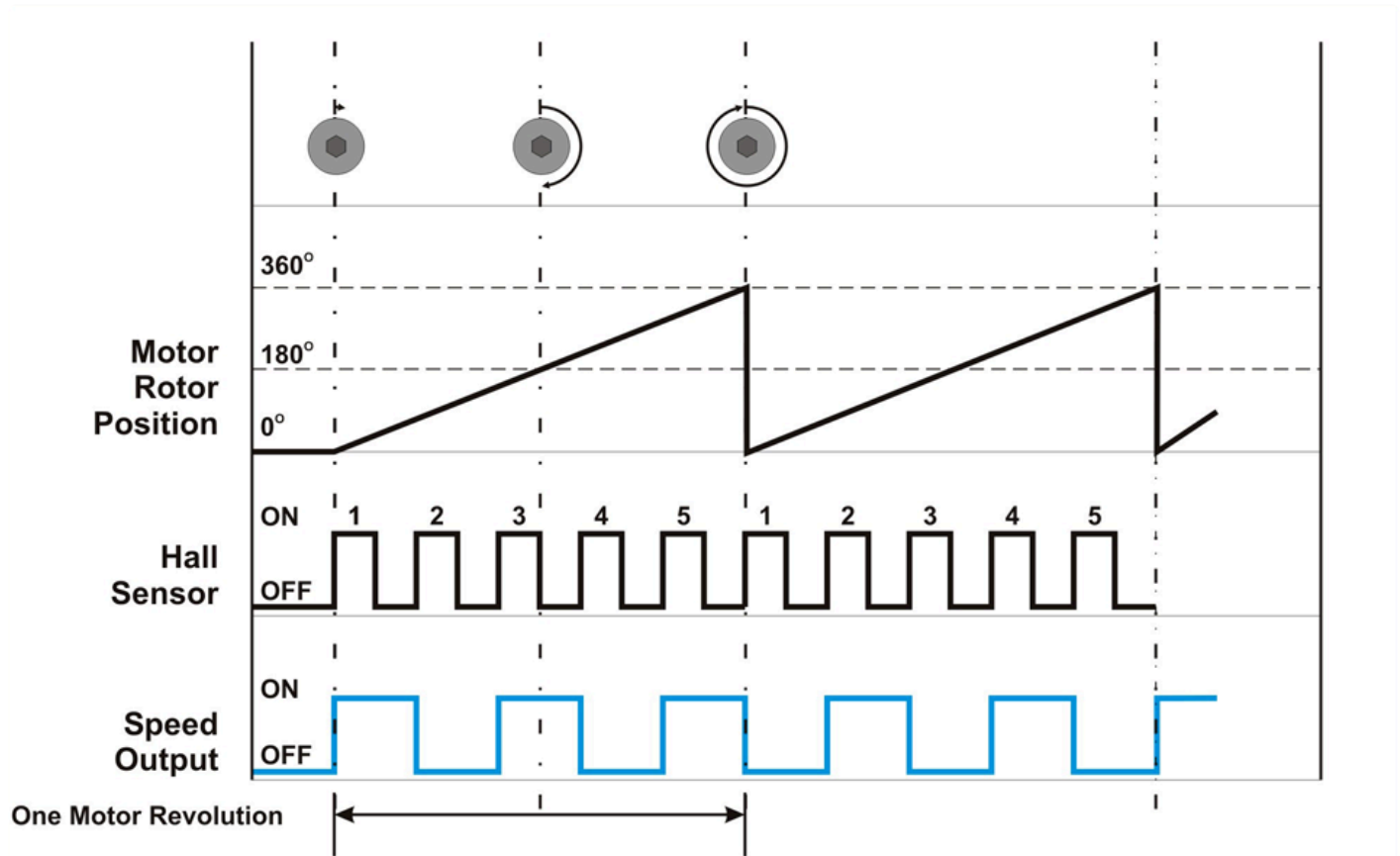

[Click here to see a list of motor speed settings and their corresponding Speed Out frequencies](#)

\* Please note that the *SPEED* output indicates the *motor's rotational frequency* and not the roller tube. Please refer to your MDR's gear reduction ratio information to calculate MDR rotational speed.

! Please note for part number [EZ-QUBE-P-MR \(Article Number 1510-6020\)](#) the Speed output is not a frequency signal but is a maintained digital output signal that is energized whenever the motor is running

# 7.2. Error Output and LED Status

## LED Status Indicators

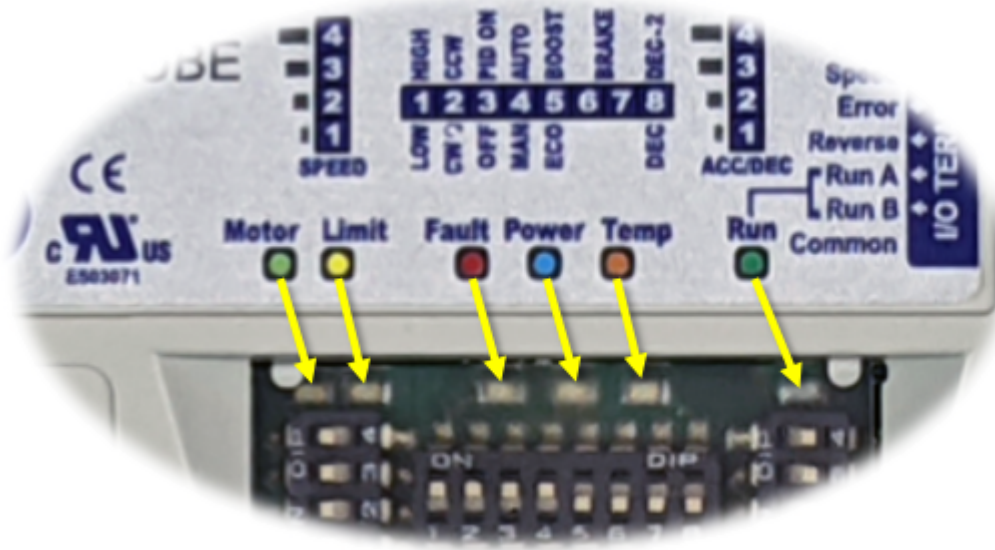

LED	LED State	Description
Power	ON at normal brightness	Input power is between 18V and 31V
	FLASH at 0.1s interval	Input power is below 18V
	ON at high brightness	Input voltage is greater than 31V
Run	ON	ON when either RUN A or RUN B or both are ON
Motor	Flashing	RUN signal(s) are on and flash rate is proportional to motor speed
Limit	ON	Current is being limited to motor
	Flash & Blink	See Timing Diagrams in the following sections
Temp	ON	Calculated motor temperature is above 105°C

Fault	0.2s Flash at 0.4 sec interval	Motor roller is disconnected
	Flash at 1.0 s interval	Controller has stopped the motor due to error condition
	Other flash rates	See Timing Diagrams in the following sections

## LED Status Timing Diagrams for Various Conditions

[Power Supply ON with Motor Connected](#)

[Motor Not Connected](#)

[Power Supply Voltage >32V](#)

[Voltage Drop Below 18V and 13V](#)

[Voltage Over 32V Due to Motor Overspeed](#)

[Normal Operation with Motor Running and then Reverse Signal](#)

[Motor Current Exceeding Peak Limit](#)

[Over Current with PWM Limiting](#)

[Motor Stalled with Self Stop](#)

[Motor Overload with Self Stop](#)

[Module Over Heat with Self Stop](#)

[Motor Not Running when RUN is ON](#)

[Motor Phases Error Detected](#)

# 7.2.1. Power Supply ON with Motor Connected

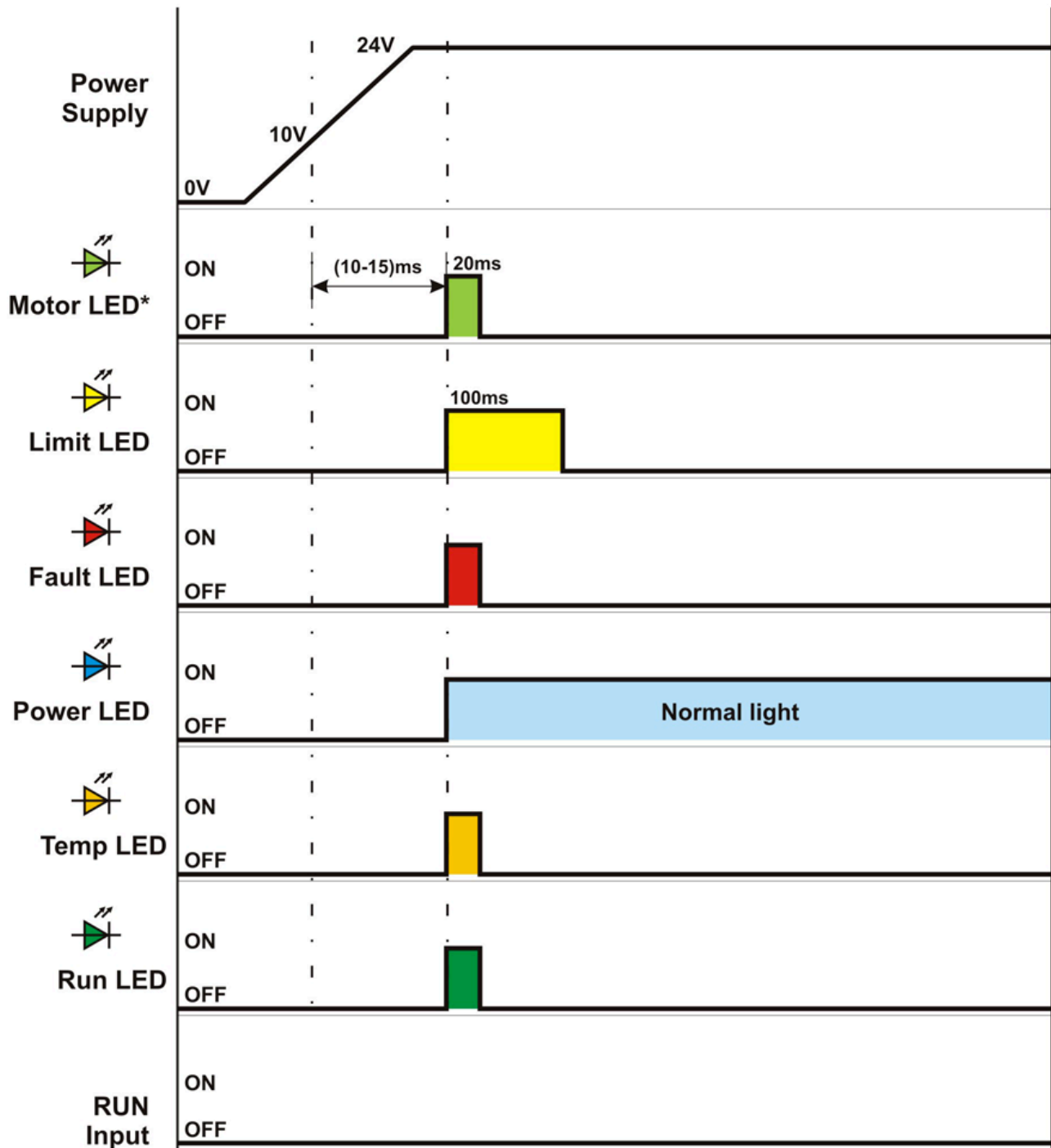

## 7.2.2. Motor Not Connected

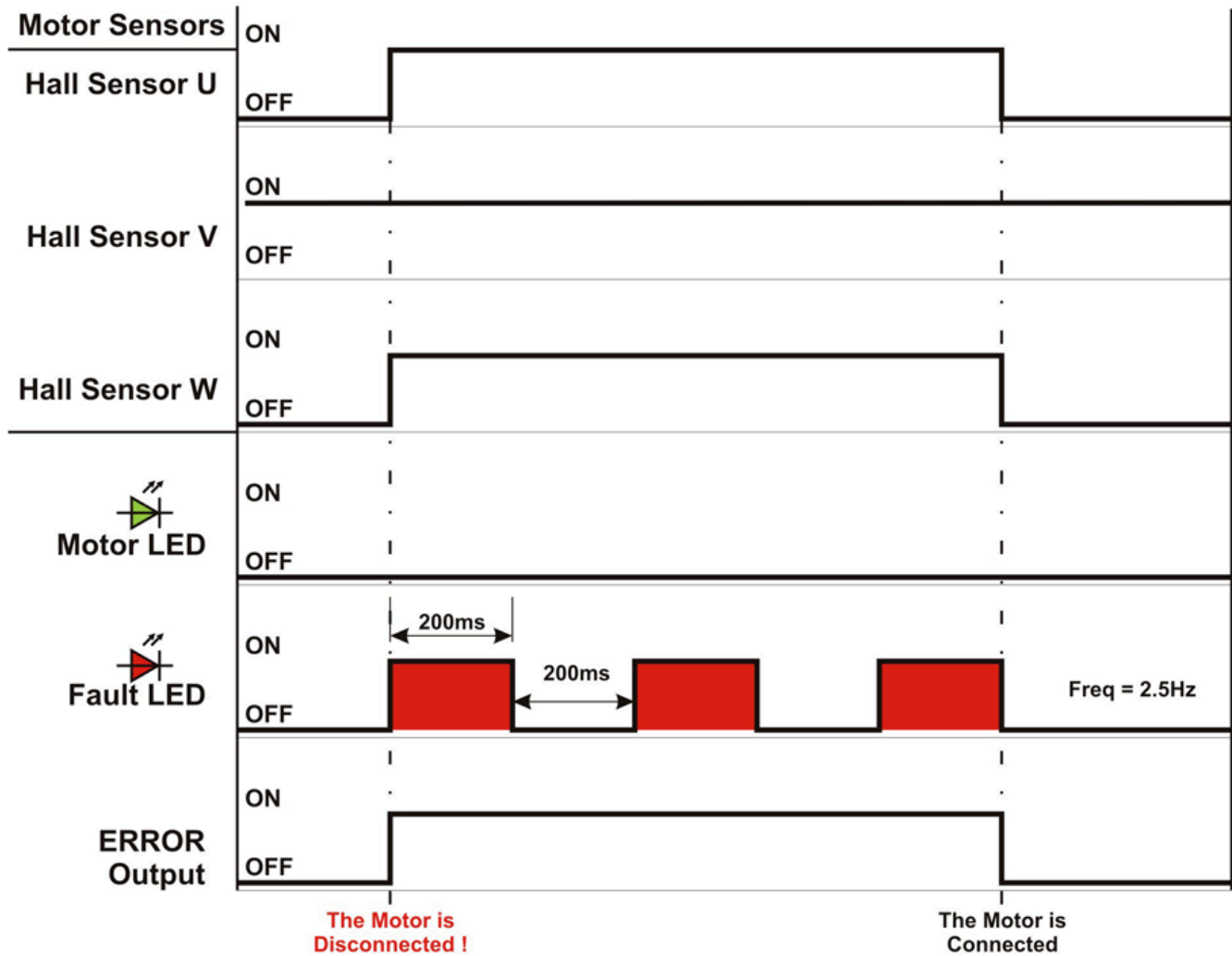

## 7.2.3. Power Supply Voltage > 32V

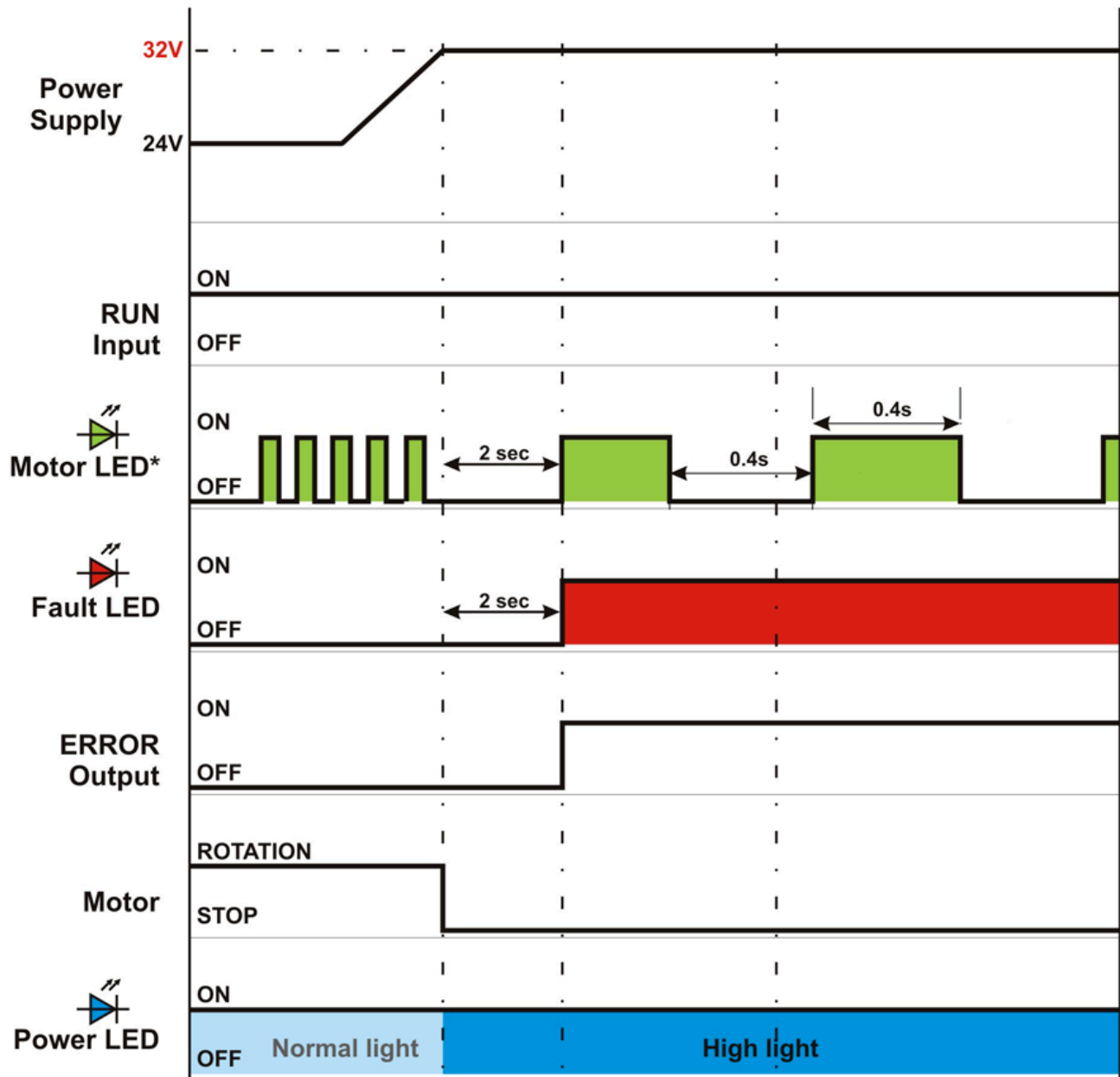

\* Frequency is proportional the rotation speed of the motor



# 7.2.4. Voltage Drop Below 18V and Voltage Drop Below 13V

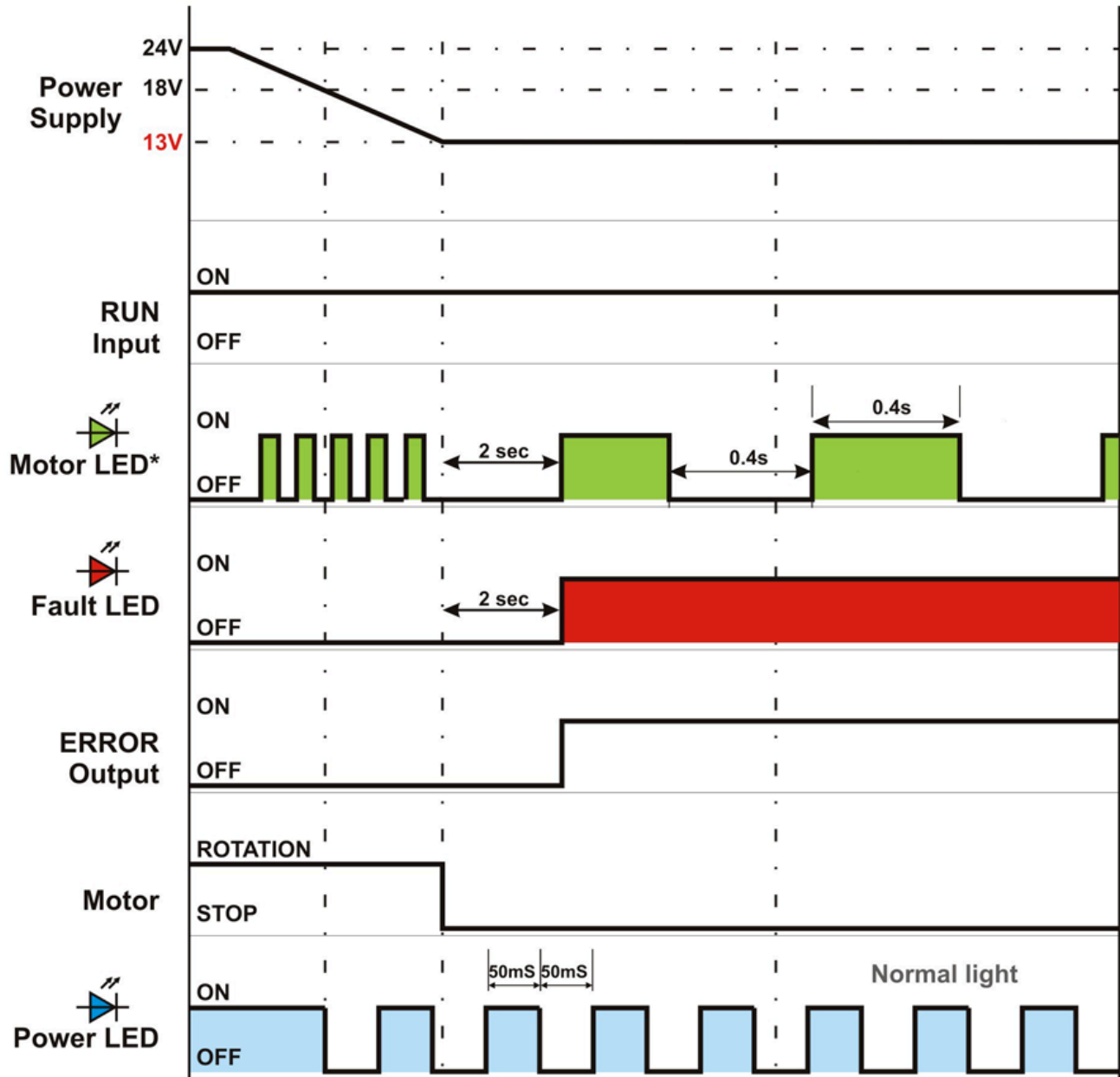

\* Frequency is proportional the rotation speed of the motor

# 7.2.5. Voltage Over 32V Due to Motor Overspeed

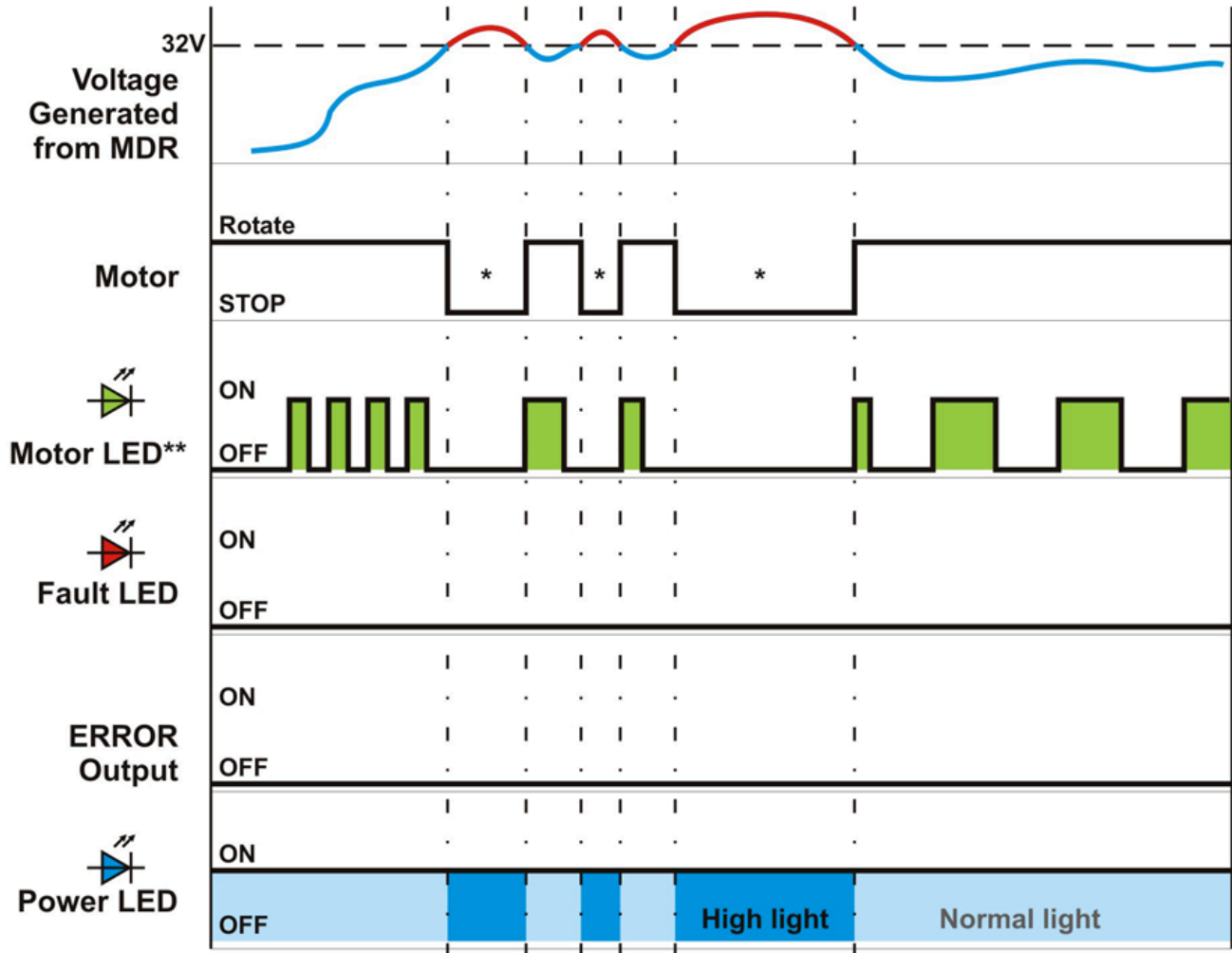

\* EZQUBE absorbs extra energy generated by the motor

\*\* Frequency is proportional the rotation speed of the motor

# 7.2.6. Normal Operation with Motor Running then Reverse Signal

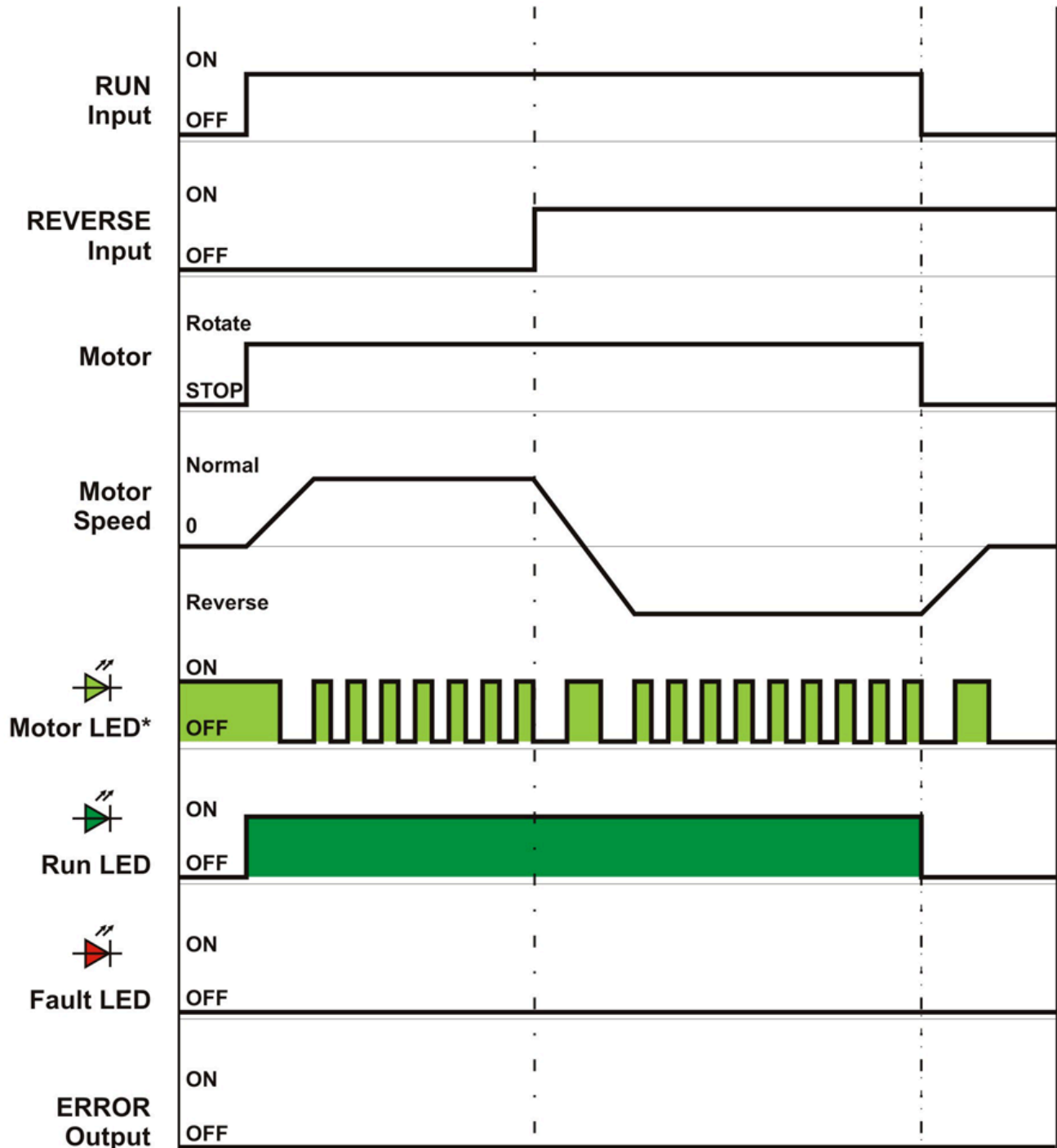

\* Frequency is proportional the rotation speed of the motor

# 7.2.7. Motor Current Exceeding Peak Limit

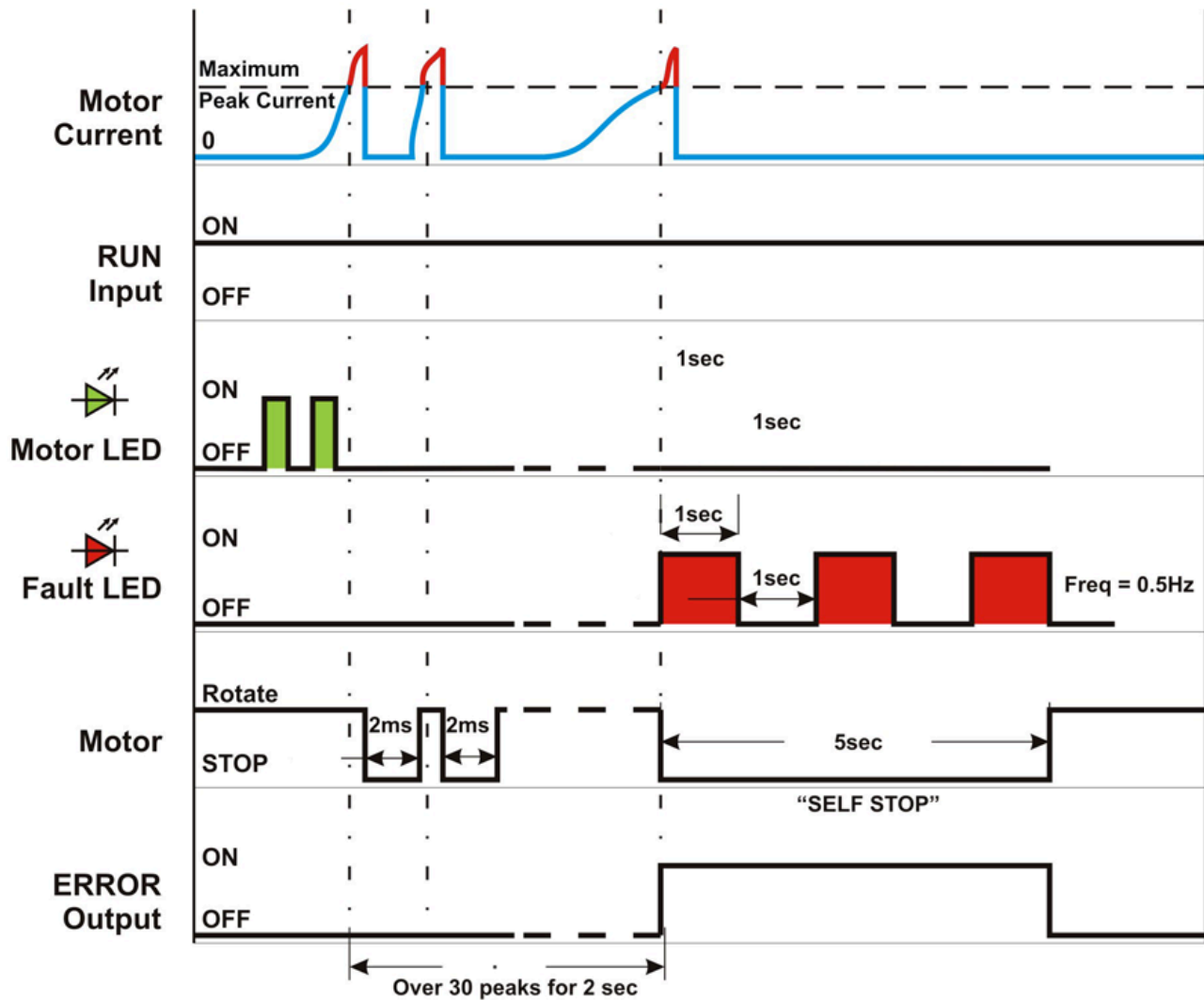

\* Diagram depicts operation when *CONFIG DIP SW 4* is set to ON (Automatic Reset) which causes the motor to automatically restart after forced stop. If *CONFIG DIP SW 4* is set to OFF (Manual Reset), then the *RUN* signal must be toggled OFF then ON again to restart the motor.

## 7.2.8. Over Current with PWM Limiting

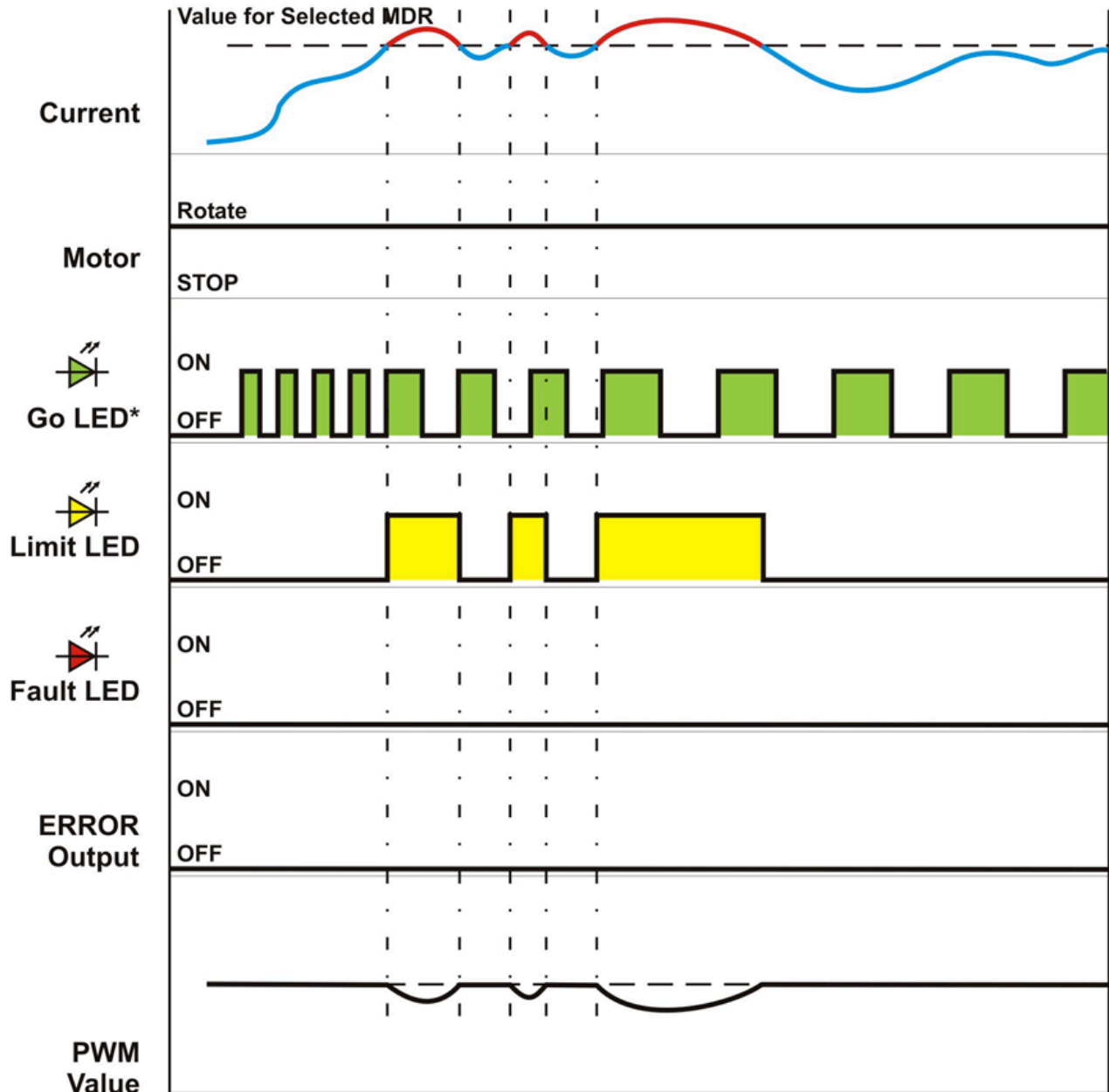

The PWM output decreases bring motor to selected current range

\* Frequency is proportional the rotation speed of the motor

# 7.2.9. Motor Stalled with Self Stop

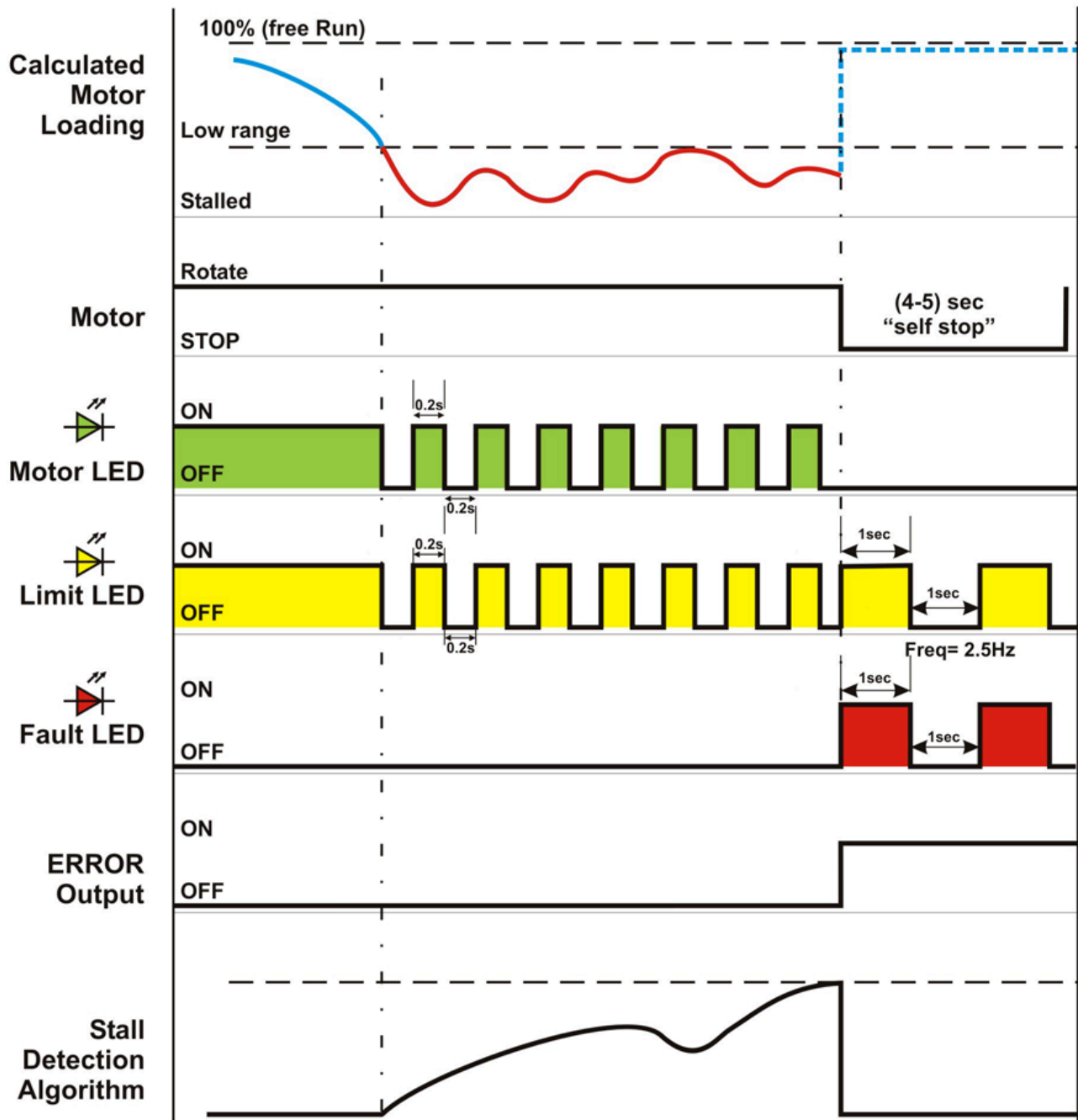

In this case if no PI loop control is used, the motor current may not exceed the upper current limit

# 7.2.10. Motor Overload with Self Stop

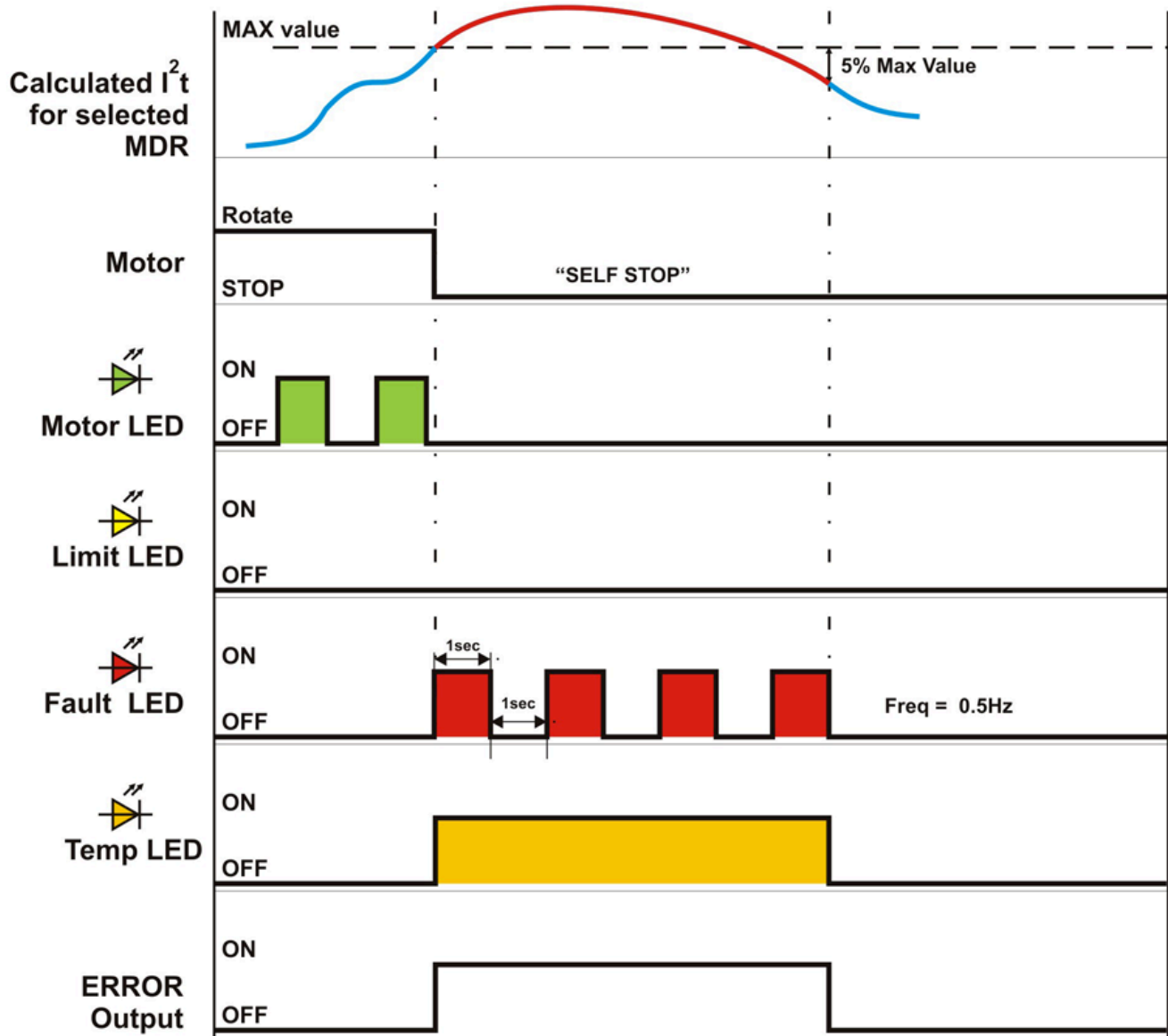

# 7.2.11. Module Over Heat with Self Stop

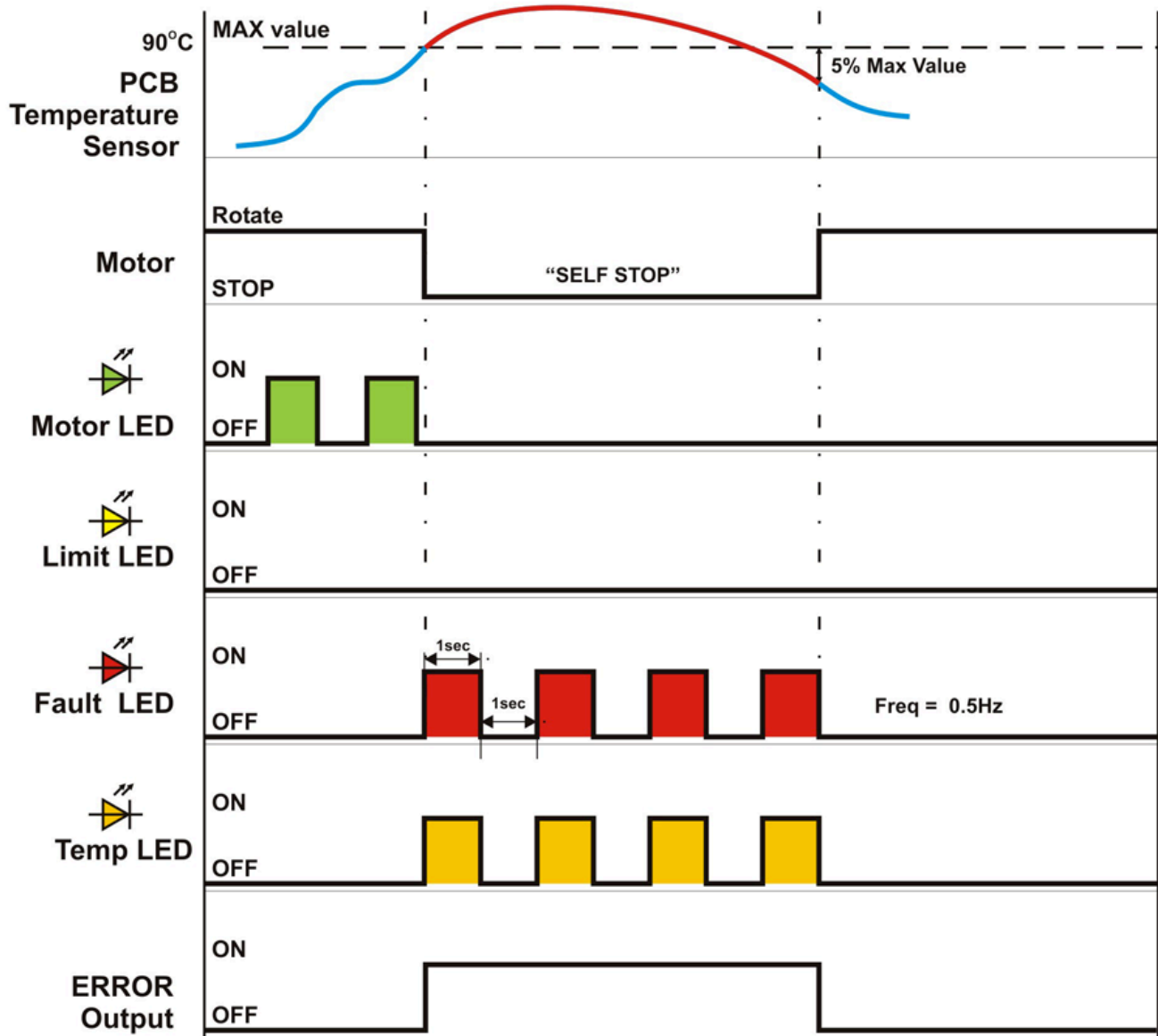



## 7.2.12. Motor Not Running when RUN is ON

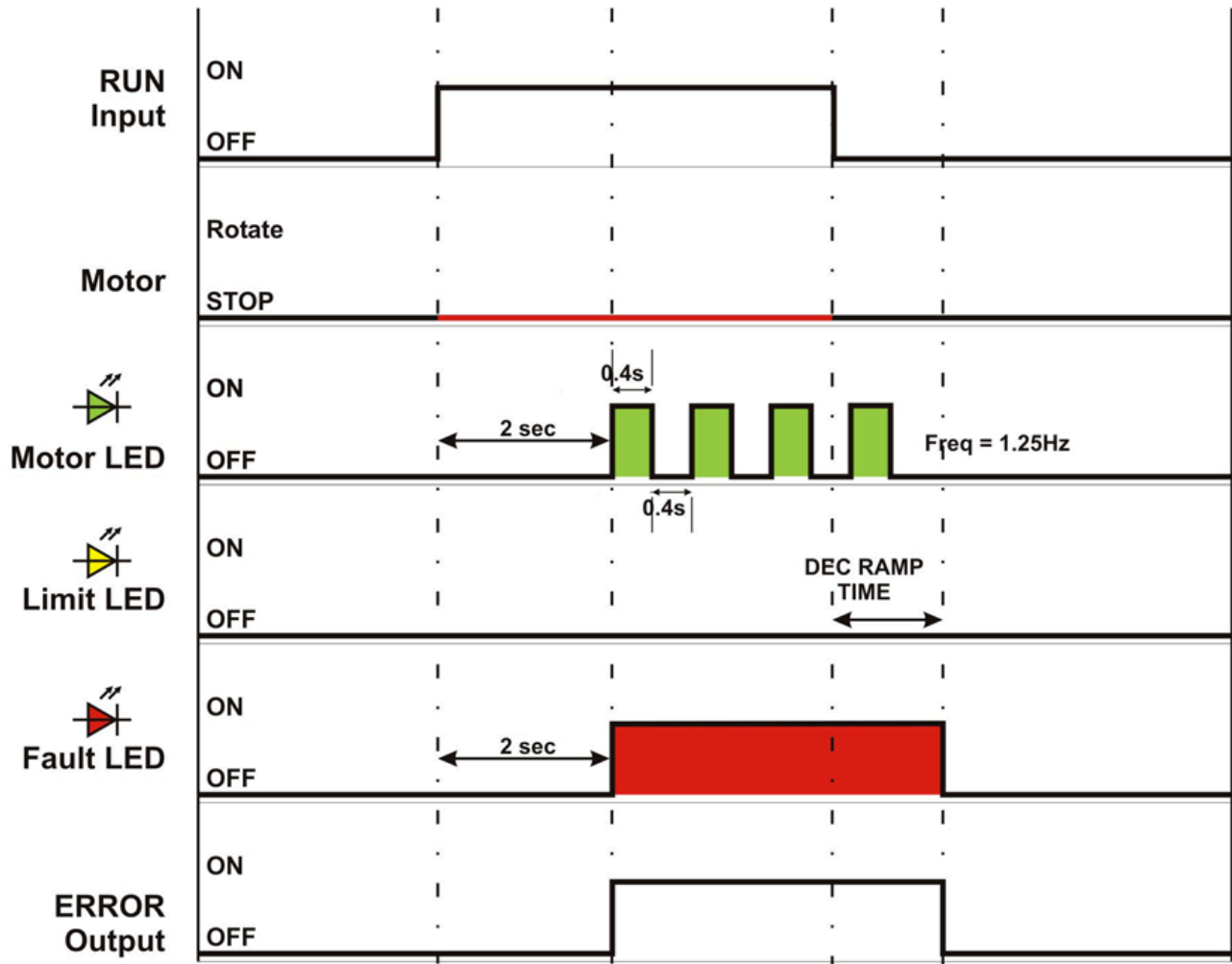

## 7.2.13. Motor Phases Error Detected

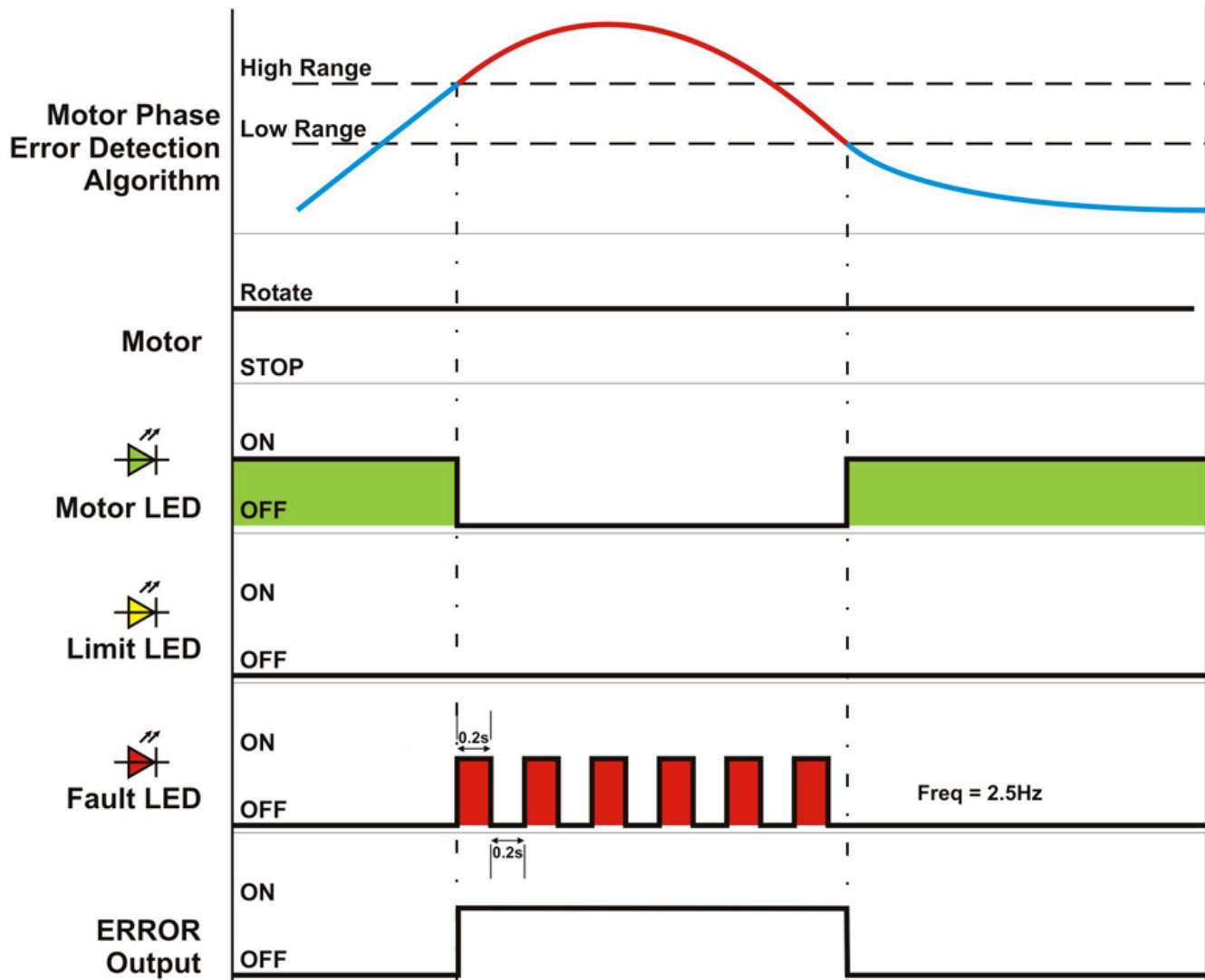

Fault phases may occur due to:

- Failed sensor
- short circuit between connecting cables
- short circuit between sensor and ground

## 8. Internal Jumper Settings

In some cases you can change the PNP/NPN operation of the SPEED and/or ERROR output signals by changing internal jumper settings on the EZ-QUBE module's circuit board







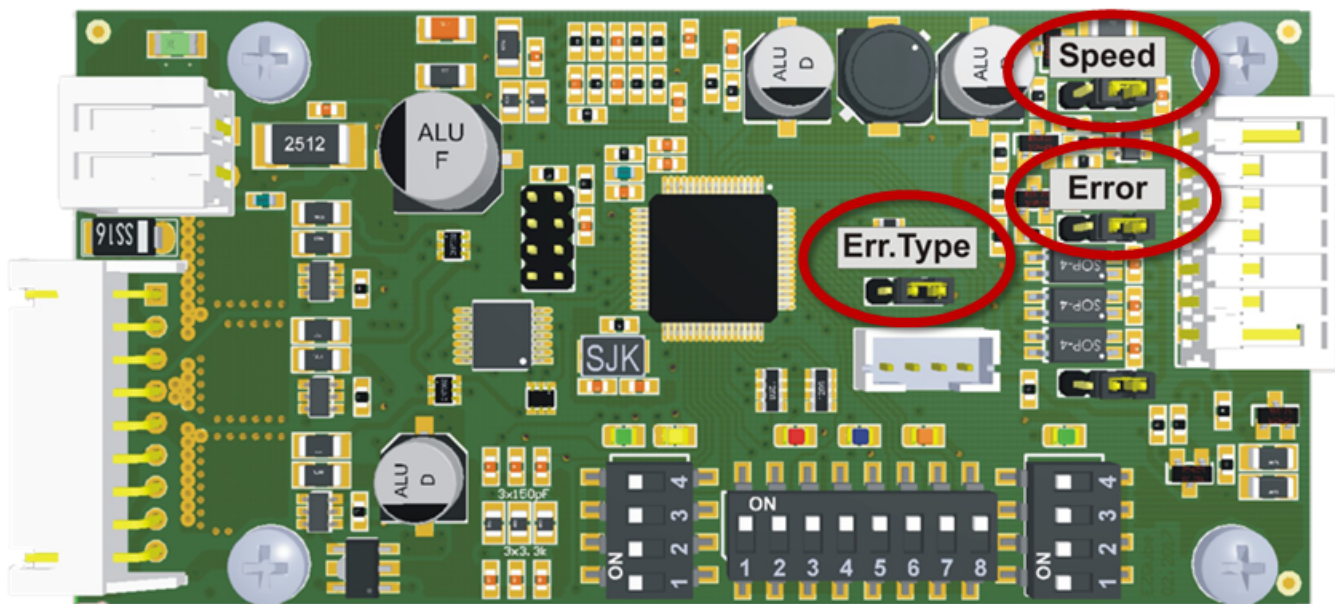

**!** CAUTION !!!! Modifying internal jumper settings involves removing the module's plastic housing cover. Handling the EZ-QUBE module without the cover must only be done by personnel who have been adequately electro-statically discharged. Handling the module with the housing cover removed without proper ESD precautions may result in module damage

On the PCB of the EZ-QUBE there are three (3) jumpers:

Jumper	Description
<i>Error</i>	Error output can be either PNP or NPN
<i>Speed</i>	Speed output can be either PNP or NPN
<i>Err.Type</i>	When Error is active, signal can be either ON or OFF



## ERROR Output States

Jumper Position		Module Version	When No Error is Active	When Error is Active
Err.Type	Error			
		NPN	ON	OFF
		NPN	OFF	ON
		PNP	OFF	ON
		PNP	ON	OFF

## SPEED Output

Jumper Position	SPEED Output
	NPN
	PNP

\* Note that the SPEED Output jumper settings are the same for either PNP or NPN Module hardware versions